



**GASONET SERVICES (RJ) LIMITED**

**PROCUREMENT OF API 5L 3LPE COATED CS LINE PIPE  
RESONANCE ENERGY PVT LTD**

**TECHNICAL VOLUME II OF II**

***TENDER NO.: GSL/REPL/012/STPL***

**OPEN DOMESTIC COMPETITIVE BIDDING**

0	19/01/2023	DG	PG	AN
<b>Rev.</b>	<b>Date</b>	<b>Prepared By</b>	<b>Checked By</b>	<b>Approved By</b>



## PROCUREMENT OF API 5L 3LPE COATED CS LINE PIPE



TENDER DOCUMENT NO:  
GSL/REPL/012/STPL

Date: 19/01/2023

### INDEX

<b><u>SL.NO.</u></b>	<b><u>DESCRIPTION</u></b>
1.0	MATERIAL REQUISITION
2.0	STANDARD SPECIFICATION FOR HIGH FREQUENCY WELDED LINE PIPE
3.0	STANDARD SPECIFICATION FOR SEAMLESS (SMLS) LINEPIPE (ONSHORE)
4.0	STANDARD SPECIFICATION FOR 3 LAYER POLYETHYLENE COATING OF LINEPIPES
5.0	STANDARD SPECIFICATION FOR SEAMLESS CARBON STEEL PIPE
6.0	I T P- WELDED PIPES
7.0	I T P SEAMLESS PIPES
8.0	I T P - 3-LAYER PE COATING OF LINE PIPES
9.0	I T P – SMALL SIZE PIPES
10.0	CHECKLIST
11.0	COMPLIANCE STATEMENT
12.0	DEVIATION SHEET
13.0	INSTRUCTION TO BIDDER
14.0	REFERENCE LIST
15.0	VENDOR DRAWINGS / DOCUMENT SCHEDULE139



## PROCUREMENT OF API 5L 3LPE COATED CS LINE PIPE



TENDER DOCUMENT NO:  
GSL/REPL/012/STPL

Date: 19/01/2023

### 1. INTRODUCTION

1.1 The consortium of Dinesh Engineers Ltd., Resonance Energy Pvt. Ltd., and Tolani projects Pvt. Ltd has been authorized by PNGRB in 11 round of bidding for four Geographical Areas (GA's) of

- 1) Mandi, Kullu, Kinnaur, and Lahaul & Spiti districts in the state of Himachal Pradesh,
- 2) Bikaner & Churu districts in the state of Rajasthan
- 3) Pauri Garhwal, Uttarkashi, Rudraprayag, Tehri Garhwal districts in the state of Uttarakhand,
- 4) Pithoragarh, Almora, Champawat, Chamoli & Bageshwar districts in the state of Uttarakhand

The consortium has establish three companies namely Gasonet Service (HP) Ltd , Gasonet Service (RJ ) Ltd , Gasonet service (UK) Ltd, and GA of one and two above has been transferred to GA of Gasonet Services (HP) Ltd , Gasonet Services ( RJ) Ltd respectively and GA of 3 and 4 above has been transferred to Gasonet Services (UK )Ltd

1.2 All These companies are engage in City Gas Distribution to supply natural gas for domestic, automobile, industrial and commercial and have corporate office at 807, World Trade ,Sector 16, Noida-201301, The corporate is managed by Gasonet service (RJ) Ltd

1.3 Resonance Energy Pvt. Ltd. (REPL) has been appointed as the Project Management Consultant for providing consultancy services for CGD Expansion Project for PNG in the State of Rajasthan (hereinafter referred as Consultant), by GSL..

### 2. SCOPE OF SUPPLY



ITEM NO.	SIZE (Inch)	THK. (mm)	MATERIAL (PSL-2)	EXTERNAL COATING	METHOD	QTY (Meter)
A	4"	6.4	API 5L Gr. X-52	3LPE	HFW/SMLS	15000
B	6"	6.4	API 5L Gr. X-52	3LPE	HFW/SMLS	60000
C	8"	6.4	API 5L Gr. X-52	3LPE	HFW/SMLS	6000
D	2"	6.4	API 5L Gr. X-52	BARE	HFW/SMLS	60
E	4"	6.4	API 5L Gr. X-52	BARE	HFW/SMLS	60
F	6"	6.4	API 5L Gr. X-52	BARE	HFW/SMLS	60

Note-

1. The above quantities are indicative only and are subject to change at the time of ordering.

#### Abbreviations

1. HFW – High frequency welded
2. SMLS – Seamless

	<b>PROCUREMENT OF API 5L 3LPE COATED CS LINE PIPE</b>	
TENDER DOCUMENT NO: GSL/REPL/012/STPL		<b>Date: 19/01/2023</b>

### 3. DOCUMENT PRECEDENCE

It shall be the responsibility of the MANUFACTURER/ VENDOR to inform the PURCHASER of any errors, ambiguities, inconsistencies, discrepancies or conflict of information that may be found to exist in any document, specification or drawing submitted by the PURCHASER.

In case of conflict, the order of precedence shall be as follows:

- a. MR
- b. Basic Documents (Specifications)
- c. Codes and Standards

As a general rule in the event of any discrepancy between technical matter and local laws/ regulations (and documents above listed) the most stringent shall be applied.

MANUFACTURER/ VENDOR shall notify PURCHASER of any apparent conflicts between MR, specifications, related datasheets, any code and standards and any other specifications noted herein. (Resolution and/ or interpretation precedence shall be obtained from PURCHASER in writing before proceeding with the design/ manufacturer or completion of services.)

### 4. GENERAL NOTES

#### A. VENDOR'S COMPLIANCE

Vendor shall submit his bid in full compliance with the requirements of this MR and attachments.

Vendor must include the following statement in his bid:

*We certify that our bid is fully complying with your enquiry dated....., and referenced & Technical variations if any are tabulated in Table # 3.*

Compliance with this material requisition in any instance shall not relieve the Vendor of his responsibility to meet the specified performance.

#### B. COMPLIANCE WITH SPECIFICATION

The VENDOR shall be completely responsible for the design, materials, fabrication, testing, inspection, preparation for shipment and transport of the above equipment strictly in accordance with the Material Requisition and all attachments there to.

#### C. VENDOR'S SCOPE

Vendor's scope of work includes supply, testing, inspection, packing & forwarding and transportation of Line Pipe to owner's stores.

#### D. RAW MATERIAL

Bidder shall place the PO for raw material (coil) and shall submit the required documents, as per



## PROCUREMENT OF API 5L 3LPE COATED CS LINE PIPE



TENDER DOCUMENT NO:  
GSL/REPL/012/STPL

**Date: 19/01/2023**

technical tender, to owner within 15 days of LOI/ First intimation/ PO. Indicative list of documents to be submitted shall include:

1. Copy of PO with detailed technical specifications and delivery terms,
2. Documentary evidence for advance payment made (If Any). Purchaser may ask for other additional documents also.

Non-submission of above documents within stipulated time frame shall be treated as non-compliance of supply contract and penalty shall be levied @ 0.2 % of awarded group value per week.

### **E. INSPECTION**

The vendor shall appoint approved Third Party Inspection Agency for carrying out the inspection as per approved ITP and TPIA charges shall be borne by vendor.

### **5. DESIGN DATA**

<b>Description</b>	<b>Value</b>
Product	Natural Gas
Design Pressure (Maximum)	49 bar
Material Specification	API 5L GR. X-52
Corrosion Protection	3 layer PE coated and Cathodic Protection

### **NOTES:**

- a. Manufacturer shall have valid API license throughout the manufacturing period.
- b. Quantity may vary  $\pm 5\%$  for coated pipe &  $\pm 25\%$  for bare pipe. Final quantity will be informed to successful bidder.
- c. Hydro test shall be carried out at 95% of SMYS and for 15 seconds.
- d. Pipes shall be supplied between 11.5 m to 12.5 m. Coating material combination shall be as per Annexure-I for carrying out 3-layer polyethylene coating. The minimum thickness of finished coating shall be as per aforesaid specification.
- e. For butt weld end, bevel shall be in accordance with API specification 5L or ASME B16.25 as applicable.
- f. Bevel Protector or end caps shall be installed on all pipe ends. End caps shall be hook-able type which shall allow the use of end hooks without the need for their removal during pipe handling. The bevel protector shall be the re-usable type.



## PROCUREMENT OF API 5L 3LPE COATED CS LINE PIPE



TENDER DOCUMENT NO:  
GSL/REPL/012/STPL

**Date: 19/01/2023**

- g. Plastic push fit types end caps shall be installed on all small diameter pipe ends.
- h. All major damage to pipe ends/ bevels, including dents or gauges, shall be repaired by removal of damaged pipe material and re-beveling. No welding on the pipe surface shall be allowed. During inspection at storage yard, if owner get a defective pipe & the pipe is un-acceptable to owner, then that pipe shall be replaced by supplier without any extra cost.
- i. Inspection of Field Test and Warranty.
- Purchaser shall be reimbursed by Manufacturer for any pipe furnished on this order that fails under field hydrostatic test if such failure is caused by a material/manufacturing defect in the pipe. The reimbursement cost shall include pipe, labour and equipment rental for finding, excavating, cutting out and installation of replaced pipe in position. The field hydrostatic test pressure will not exceed that value which will cause a calculated hoop stress equivalent to 95 percent of specified minimum yield strength.
- In case Manufacturer so desires, he will be advised at least two weeks in advance so that his representative may witness the hydrostatic test in field, however, the testing and leak (if any) finding and repair operation shall not be postponed because of absence of the Manufacturer's Representative.
- j. Charpy impact test for API 5L Line Pipe shall be carried out as specified in specification. However, first day MPQT shall be as per Annex B.
- k. Bare Seamless Carbon Steel Pipe material shall be subjected to Charpy V-notch tests at (-) 29°C for CS. The minimum average value of the test shall be 27 J and for individual test piece it shall be 22 J. The impact test shall be carried out as per ASTM A370. Hardness test shall be carried out and hardness value shall not exceed 248HV10.
- l. Each length of the Bare Seamless Carbon Steel pipe shall be subjected to the hydrostatic test without leakage. The Hydrostatic test pressure shall be as per ASTM A530.
- m. Bidder shall furnish quotation only in case he can supply material strictly as per this MR and specification forming part of MR.
- n. ITP for line pipe are enclosed with Bid. Bidder to follow the same.
- o. If the offer contains any technical deviations or clarifications or stipulates any technical specifications (even if in line with MR requirements) and does not include complete scope & technical/ performance data required to be submitted with the offer, the offer shall be liable for rejection.
- q. The submission of prices by the Bidder shall be construed to mean that he has confirmed compliance with all technical specifications of the corresponding item(s).
- r. Inspection and tests performed/witnessed by purchaser's inspector shall in no way relieve the



## PROCUREMENT OF API 5L 3LPE COATED CS LINE PIPE



TENDER DOCUMENT NO:  
GSL/REPL/012/STPL

Date: 19/01/2023

manufacturer`s obligation to perform the required inspection and test.

- s. Bidder must submit all documents/ drawings/ calculations as specified in relevant specification along with his offer and after award of order.
- t. Purchaser`s inspector reserves the right to perform stage wise inspection and witness tests, as indicated in specification at manufacture`s works prior to shipment. Manufacturer shall give reasonable notice of time and shall provide without charge reasonable access and facilities require for inspection to the purchaser`s inspector. Inspection and tests performed/witnessed by purchaser`s inspector shall in no way relieve the manufacturer`s obligation to perform the required inspection and test.

### 6. DOCUMENTS & DATA REQUIREMENTS

- a. The table hereunder specifies the quantities and the nature of the documents to be submitted by the Manufacturer to the PMC.
- b. The documents required at the inquiry stage and to be included in the bid are listed under column A.
- c. The documents required after award of the AGREEMENT and subject to the written approval of the PMC are listed under column B.
- d. The final and certified documents are listed under column C.
- e. Any document, even when preliminary, shall be binding and therefore duly identified and signed by the Manufacturer. It shall bear the PMC Project reference, the Material Requisition number and the identification number.
- f. The documents are fully part of the supply which shall be complete only if and when the documents complying fully with the material requisition requirements are received by the engineer.

Item	Documents and Data	A		B		C	
		Number of copies	Number of copies	Required date	Number of copies	Required date	
1.	Drawing/data submittal list and schedule	3	4	1 week + monthly	4	2 weeks after approval	
2.	Production, test and delivery schedule (per item)	3	4	1 week + monthly	4	2 weeks	

**PROCUREMENT OF API 5L 3LPE COATED CS LINE PIPE**TENDER DOCUMENT NO:  
GSL/REPL/012/STPL**Date: 19/01/2023**

3.	Progress report	--	4	Daily + weekly + monthly	--	--
Item	Documents and Data	A	B		C	
		Number of copies	Number of copies	Required date	Number of copies	Required date
4.	Catalogues / References	3	--	--	--	--
5.	Description of application and quality with technical data of 3LPE foreexternal coating	3	4	3 weeks	4	2 weeks after approval + with final techn. File
6.	Code compliance certificate (Quality manual, ISO certificate, API License)	3	4	3 weeks	4	2 weeks after approval
7.	QA/QC program ( MPQT + Regular production separately )	--	4	2 weeks	4	2 weeks after approval
8.	Inspection and test procedures	--	4	3 weeks	3	2 weeks after approval + with final techn. file
9.	A description with calculation for handling, storage, transportation procedure during total manufacturing cycle and long storage procedure	--	4	4 weeks	--	--
10.	Duly filled & signed Technical Questionnaire & documents as per Checklist.	3	--	--	--	--
11.	List of fabrication and control operations (LOFC)	--	4	2 weeks	4	2 weeks after approval
12.	NDE reports & Procedure	--	4	When available	4	2 weeks after approval + with final techn. file

**PROCUREMENT OF API 5L 3LPE COATED CS LINE PIPE**TENDER DOCUMENT NO:  
GSL/REPL/012/STPL**Date: 19/01/2023**

Item	Documents and Data	A	B		C	
		Number of copies	Number of copies	Required date	Number of copies	Required date
13.	Heat treatment reports (When available)	--	4	When available	4	2 weeks after approval + with final techn. file
14.	Hydrotest and air test report (When available)	--	4	When available	4	2 weeks after approval + with final techn. file
15.	Material certificate	--	4	1 week after test	4	With final techn. file
16.	List of subcontractors with their scope (In case awarded to others).	3	4	2 weeks	--	With final techn. file
17.	Copy of purchase orders to subcontractors	3	4	2 weeks	--	With final techn. file
18.	Copy of purchase order	--	--	--	--	With final techn. file
19.	Packing/shipping list w/weights and dimensions	--	4	4 weeks	4	2 weeks before shipping
20.	Final technical file	--	--	--	6	With shipping

**Notes:**

- Durations in column B (Required date) are weeks after Purchase Order date.  
Durations in column C (Required date) are weeks after document approval. Due date of each document may be proposed.
- Latest submittal time for:
  - Test Procedure : 2 weeks before test
  - Test Report : 2 weeks after test
- Final technical file shall be supplied in hard copy as indicated, and in electronic format (PDF Acrobat files) on two (2) CD-ROMs.



**PROCUREMENT OF API 5L 3LPE COATED CS LINE PIPE**



TENDER DOCUMENT NO:  
GSL/REPL/012/STPL

**Date: 19/01/2023**

**STANDARD SPECIFICATION  
FOR  
HIGH FREQUENCY WELDED (HFW) LINE PIPE**



**PROCUREMENT OF API 5L 3LPE COATED CS LINE PIPE**



TENDER DOCUMENT NO:  
GSL/REPL/012/STPL

**Date: 19/01/2023**

- 1 SCOPE
- 2 NORMATIVE REFERENCES
- 3 PIPE GRADE, STEEL GRADE AND DELIVERY CONDITION
- 4 MANUFACTURING
- 5 ACCEPTANCE CRITERIA
- 6 INSPECTION
- 7 MARKING
- 8 COATINGS AND THREAD PROTECTORS
- 9 RETENTION OF RECORDS
- 10 PRODUCTION REPORT
- 11 INSPECTION OF FIELD TESTS & WARRANTY



## PROCUREMENT OF API 5L 3LPE COATED CS LINE PIPE



TENDER DOCUMENT NO:  
GSL/REPL/012/STPL

Date: 19/01/2023

### **1 SCOPE**

#### **1.1 Coverage**

This specification establishes the minimum requirements for the manufacture of high frequency welded steel line pipe in accordance with the requirements of API (American Petroleum Institute) Specification 5L, Forty-Sixth Edition, April 2018 and makes restrictive amendments to API Specification 5L. Unless modified and/or deleted by this specification, the requirements of API Specification 5L shall remain applicable.

The sections, paragraphs and annexes contained herein have the same numbering as that of API Spec 5L in order to facilitate reference. Additional requirements, which are not specified in API Spec 5L, have also been numbered and marked as "(New)".

The coverage by this specification is limited to line pipe to be used in onshore pipelines transporting non-sour hydrocarbons in liquid or gaseous phase. The product specification level for line pipe to be supplied as per this specification shall be "PSL 2".

#### **1.2 Application of the API Monogram**

The Manufacturer shall have a valid license to use API Monogram and line pipes supplied as per this specification shall bear API monogram in accordance with the requirements of

Annex A of API Specification 5L, Forty—Sixth Edition, April 2018 for Product Specification Level PSL 2.

#### **1.3 Pipe Size**

This Specification shall be applied to line pipe of size 4.5" (114.3 mm) OD thru 20" (508.0mm) OD (both sizes included).

### **2 NORMATIVE REFERENCES**

The latest edition (edition enforce at the time of issue of enquiry) of following additional references are included in this specification:

ASTM E112-13: Standard Test Methods for Determining Average Grain size

### **3 PIPE GRADE, STEEL GRADE AND DELIVERY CONDITION**

#### **3.1 Pipe Grade and Steel Grade**

Line pipe supplied to this specification shall conform to Product Specification Level 2 (PSL2) as given in Table 1 of this specification and consists of an alpha or alphanumeric designation that identifies the strength level of the pipe. The steel name (designating a steel grade), linked to the chemical composition of the steel, additionally includes a suffix that consists of a single letter (M) that identifies the delivery condition as per Table 3 of this specification.



	<b>PROCUREMENT OF API 5L 3LPE COATED CS LINE PIPE</b>	
TENDER DOCUMENT NO: GSL/REPL/012/STPL		<b>Date: 19/01/2023</b>

Table 1 of API Spec 5L stands replaced by Table 1 of this specification

PSL	Delivery Condition	Pipe grade/ steel grade <sup>a, b.</sup>
PSL -2	Thermomechanical rolled	BM, X46M, X52M,
a Deleted b The suffix (M) for PSL 2 grades belongs to steel grade		

#### Delivery condition

The delivery condition for starting material shall be in accordance with Table 1 of this specification.

## 4 MANUFACTURING

### 4.1 Process of Manufacture

Pipe furnished to this specification shall be manufactured in accordance with the applicable requirements and limitations given in Table 2 of API Spec 5L and Table 3 of this specification.

Table 3 of API Spec 5L stands replaced by Table 3 of this specification.

**Table 3 - Acceptable manufacturing routes for PSL 2 pipe**

Type of Pipe	Starting Material	Pipe forming	Pipe Heat treatment	Delivery condition
HFW	Thermomechanical-rolled coil	Cold forming	Heat treating <sup>a</sup> of weld area only	M
<sup>a</sup> See clause 4.3 of this specification for applicable heat treatment				

High frequency electric welding shall be performed with a minimum welding current frequency of 200 kHz. The welding system shall have an integrated control in which following data as a minimum shall be monitored:

- Welding Temperature
- Welding speed
- Current and Voltage

Abutting edges of the coil shall be milled or machined immediately before welding. The width of the coil shall be continuously monitored.

**4.2 Starting Material**

4.2.1 Line pipe furnished to this specification shall be made from steel produced in basic oxygen or electric arc furnace. Steel shall be made by continuous casting only.

4.2.1 The steel used for manufacture of pipe shall be fully killed and fine grained with ASTM grain size number 7 or finer as per ASTM E 112.

**4.3 Treatment of Weld Seams in EW and LW Pipes**

**4.3.2 LW pipe and PSL 2 HFW pipe**

The weld seam and the entire Heat Affected Zone (HAZ) shall be heat treated so as to stimulate a normalizing heat treatment in order to control the grain structure so that no un-tempered martensite remains in the weld seam and the HAZ, and the mechanical properties of heat treated zone approximate that of the parent metal.

Heat treatment temperature of the weld seam and the entire HAZ shall be continuously measured and recorded.

**4.4 Cold Sizing and Cold Expansion**

4.4.1 Pipes furnished to this specification shall be non-expanded.

**4.5 Jointers**

4.5.1 Jointers on pipes are not permitted.

**5 ACCEPTANCE CRITERIA**

**5.2 Chemical composition**

5.2.2 For pipes supplied as per this specification, the chemical composition of each heat of steel on product analysis shall be as given in Table 5 of this specification.

Table 5 of API Spec 5L stands replaced by Table 5 of this specification.

**Table 5 - Chemical composition for pipe**

Element	Mass fraction based upon heat and product analyses (%)	
C <sup>b</sup>	0.16	max. (For Grade BM to X56M)
	0.12 <sup>f</sup>	max. (For Grade X60M to X70M)
	0.15 <sup>m(new)</sup>	min.

**PROCUREMENT OF API 5L 3LPE COATED CS LINE PIPE**TENDER DOCUMENT NO:  
GSL/REPL/012/STPL**Date: 19/01/2023**

Si	0.45	max.
Mn <sup>b</sup>	1.20	max. (For Grade BM to X46M)
	1.40	max. (For Grade X52M & X56M)
	1.60	max. (For Grade X60M & X65M)
	1.70	max. (For Grade X70M)
P	0.020	max.
S	0.015	max.
V	0.05	max. (For Grade BM to X46M)
	<sup>d</sup>	max. (For Grade X52M to X70M)
Nb	0.05	max. (For Grade BM to X46M)
	<sup>d</sup>	max. (For Grade X52M to X70M)
Ti	0.04	max. (For Grade BM to X46M)
	<sup>d</sup>	max. (For Grade X52M to X70M)
Al <sup>n (new)</sup>	0.02 <sup>o(new)</sup>	min.
	0.07	max.
Cr	0.20	max.
Mo	0.10	max. (For Grade BM to X65M)
	0.20	max. (For Grade X70M)
Cu	0.35	max.
Ni	0.20	max.
N <sup>n (new)</sup>	0.012	max.
B	0.0005	max.



# PROCUREMENT OF API 5L 3LPE COATED CS LINE PIPE



TENDER DOCUMENT NO:  
GSL/REPL/012/STPL

Date: 19/01/2023

a Based upon product analysis as per clause 9.2.4 and 9.2.5 of API Spec 5L, the  $CE_{Pcm}$  limits apply if  $C \leq 0.12\%$  and  $CE_{IIW}$  limits apply if  $C > 0.12\%$ . For pipes of all grades, sizes and wall thicknesses, Carbon Equivalent shall comply with the following limits:

$CE_{Pcm} \leq 0.20\%$

$CE_{IIW} \leq 0.40\%$

Boron content shall be considered in  $CE_{Pcm}$  formula even if it is less than 0.0005%.

b Deleted

Deleted

$d Nb + V + Ti \leq 0.15\%$

e Deleted

Deleted

Deleted

Deleted

Deleted

Deleted

Deleted

Deleted

(New)m: Minimum for Si is not applicable for AI killed steel.

(New)n: AI/N shall be minimum 2 (not applicable to titanium-killed steel or titanium-treated steel).

(New)o : Applicable for AI killed steel.

5.2.3 For heat analysis and product analysis, all the elements listed in Table 5 of this specification shall be analysed and reported, even if those are not purposely added but are present as residuals only.

If alloying elements other than those specified in Table 5 of this specification are added to the steel, the limits of the additional components shall be agreed with the Purchaser.

### Tensile properties

The finished pipe (after all heat treatment & sizing operations) shall conform to the requirements of Table 7 of API Spec 5L and as modified herein.

The actual yield strength shall be as close as possible to the specified minimum yield strength (SMYS) but in no case it shall exceed the limits specified here under:

API Spec 5L Grade	Permissible in excess of SMYS, MPa (psi)
Up to and including X46 M	131 (19,000)
X52M to X60M	125 (18,000)



## PROCUREMENT OF API 5L 3LPE COATED CS LINE PIPE



TENDER DOCUMENT NO:  
GSL/REPL/012/STPL

Date: 19/01/2023

X65M to X70M

120 (17,400)

The ratio of body yield strength and body tensile strength of each test pipe on which yield strength and ultimate tensile strength are determined, shall not exceed 0.90.

The tensile strength of the weld (after heat treatment of the weld seam) shall be equal to or higher than the specified minimum tensile strength of the base metal.

The minimum elongation of base metal shall be determined in accordance with the formula given in foot note (f) of Table 7 of API Spec 5L, however, minimum elongation in no case shall be less than 20%.

### 5.4 Flattening Test

Acceptance criteria for flattening tests shall be as follows:

**5.4.2** For HFW pipe of grade  $\geq$  X60 and  $t \geq 12.7$  mm, there shall be no opening of the weld before the distance between the plates is less than 66% of the original outside diameter. For all other combinations of pipe grade and specified wall thickness, there shall be no cracks or breaks in either weld or parent metal before the distance between the plates is less than 50% of the original outside diameter. Dye penetrant testing shall be used to positively confirm the presence of crack, break or opening.

**5.4.3** For HFW pipe with a  $D/t > 10$ , there shall be no cracks or breaks other than in the weld before the distance between the plates is less than 33% of the original outside diameter.

**5.4.4** For all pipes, there shall be no evidence of lamination or burnt metal during the entire test before opposite walls of the pipe meet.

Note: The weld extends to a distance of 13 mm on each side of the weld line. The original outside diameter is the specified outside diameter.

### 5.5 CVN Impact Test for PSL 2 Pipe

#### 5.5.2 General

5.5.2.2 From the set of three Charpy V-notch impact test pieces, only one is allowed to be below the specified average absorbed energy value and shall meet the minimum single absorbed energy value requirement as specified in Table 8 of this specification.

#### 5.5.3 Pipe body tests

5.5.3.1 The average (set of three test pieces) absorbed energy value (KvT) for each pipe body test shall be as specified in Table 8 of this specification, based upon full sized test pieces at a test temperature of 0°C (32°F) and at -29° C (-20°F).

Table 8 of API Spec 5L stands replaced by Table 8 of this specification.

**Table 8 - CVN absorbed energy requirements**

for pipe body, weld and HAZ of PSL 2 pipe

Pipe Grade	Full-size CVN absorbed energy (KvT) <sup>a,b</sup> [J]	
	Average	Minimum
BM	40	32
X42M	40	32
X46M	40	32
X52M	40	32
X56M	40	32
X60M	42	34
X65M	45	36
X70M	50	40

a. The required KvL (longitudinal direction test pieces) values shall be 50% higher than the required KvT values.  
 b. Testing shall be performed at a test temperature of 0° C (32°F) and at -29°C (-20°F).  
 c. The minimum average (of a set of three test pieces) absorbed energy for each pipe weld and HAZ test, based on full-size test pieces and a test temperature of -29 ° C (-20°F) shall be 27 J & for individual test piece it shall be 22 J.(Applicable only for -29°C, for other temperatures refer table above.)

5.5.3.2 The minimum average (set of three test pieces) shear fracture area shall be at least 85 % with one minimum value of 75%, based at a test temperature of 0 °C (32°F) and at -29°C (-20°F).

**5.5.4 Pipe weld and HAZ tests**

The average (set of three test pieces) absorbed energy value (KvT) for each pipe weld and HAZ test shall be as specified in Table 8 of this specification, based upon full-size test pieces at a test temperature of 0°C (32°F) and at -29° C (-20°F).

**5.6 Surface Conditions, Imperfections and Defects**

**5.6.2 General**

5.6.2..2 All pipes shall be free from cracks, sweats, leaks and slivers. Pipe containing such defects shall be treated in accordance with clause C.3 b) or c) of API Spec 5L.

**5.6.3 Arc burns**

5.6.3.2 Arc bums shall be treated in accordance with clause C.3 b) or c) of API Spec 5L. As a reference method for confirming the existence of an arc bum, the area shall be buffed with wire brush or sanding disc and etched with 10% solution of ammonium per sulfate or a 5% solution of nital.



## PROCUREMENT OF API 5L 3LPE COATED CS LINE PIPE



TENDER DOCUMENT NO:  
GSL/REPL/012/STPL

Date: 19/01/2023

However, arc bums can be considered for acceptance, in case the same is re- crystallized by seam heat treatment. In such case, the Manufacturer shall demonstrate the re-crystallization to Purchaser by taking a sample as per clause 6.2.3.5 (New) of this specification.

### 5.6.4 Laminations

Any lamination or inclusion either extending into the face or bevel of the pipe or present within 50 mm from pipe ends shall be classified as defect. Pipes that contain such defects shall be rejected or cut back until no lamination or inclusion is present at the pipe ends and shall be treated in accordance with clause C.3 b) or c) of API Spec 5L.

### 5.6.5 Geometric deviations

5.6.5.2 For dents, the length in any direction shall be  $\leq 0.5 D$  and the depth, measured as the gap between the extreme point of the dent and the prolongation of the normal contour of the pipe, shall not exceed the following:

- a) 3.2 mm for cold-formed dents with sharp-bottom gouges and not encroaching upon the specified minimum wall thickness
- b) 6.4 mm for other dents
- c) 1 mm at the pipe ends, i.e. within a length of 100 mm at each of the pipe ends.
- d) Any dent on weld and heat affected zone (HAZ).

Dents that exceed the above specified limits shall be considered as defect and shall be treated in accordance with clause C.3 b) or c) of API Spec 5L. Acceptable cold- formed dents with sharp-bottom gouges shall be treated in accordance with clause C.2 of API Spec 5L & as modified in this specification.

### 5.6.6 Hard Spots

Any hard spot larger than 50 mm (2.0 in) in any direction and hardness greater than 248HV<sub>10</sub> shall be classified as defect and treated in accordance with clause C.3 b) or C.3 c) of API Spec 5L.

### 5.6.7 Other surface imperfection

Other surface imperfections found by visual inspection or non-destructive inspection shall be investigated, classified and treated as follows:

- a) Imperfections that have a depth  $\leq 0.05 t$  and do not encroach on the minimum specified wall thickness shall be classified as acceptable imperfections and shall be treated in accordance with Clause C.1 of this specification.



# PROCUREMENT OF API 5L 3LPE COATED CS LINE PIPE



TENDER DOCUMENT NO:  
GSL/REPL/012/STPL

Date: 19/01/2023

- b) Imperfections that have a depth  $> 0.05 t$  and do not encroach on the minimum specified wall thickness shall be classified as defects, and shall be dressed-out by grinding in accordance with Clause C.2 of API Spec 5L and as modified in this specification or shall be treated in accordance with clause C.3 b) or c) of API Spec 5L.
- c) Imperfections that encroach on the minimum specified wall thickness shall be classified as defects and treated in accordance with clause C.3 b) or c) of API Spec 5L.

## 5.7 Dimensions, Mass and Tolerances

### 5.7.1 Tolerances for diameter, wall thickness, length and straightness

- 5.7.1.1 The diameter and out-of-roundness shall be within the tolerances given in Table 10 of this specification.

Table 10 of API Spec 5L stands replaced by Table 10 of this specification.

**Table 10 - Tolerances for diameter and out-of-roundness**

Specified outside Diameter (D) mm (inch)	Diameter tolerances <sup>d</sup>		Out-of-roundness <sup>e (new)</sup>	
	Pipe except the end <sup>a</sup>	Pipe end <sup>a,c</sup>	Pipe except the end <sup>a</sup>	Pipe end <sup>a,c</sup>
$D \leq 168.3$ (6 5/8)	$\pm 0.0075 D$	-0.4 mm to +1.6mm	0.020D	0.015 D up to a maximum of 2.0mm
$168.3$ (6 5/8) $< D \leq 273.1$ (10 3/4)	$\pm 0.0075 D$	$\pm 0.005 D$	0.020D	2.0 mm
$D > 273.1$ (10 3/4)	$\pm 0.0075 D$ up to a maximum of $\pm 3.0$ mm	$\pm 1.6$ mm	0.020D	3.0 mm

a. The pipe end includes a length of 100 mm at each of the pipe extremities.

b. Deleted

c. The diameter tolerance and out-of-roundness tolerance shall apply on inside diameter.

The inside diameter, based on circumferential measurement, shall be calculated as  $ID = (D - 2t)$ .

d. For determining compliance to the diameter tolerances, the pipe diameter is defined as the circumference of the pipe in any circumferential plane divided by  $\pi$ .

e. (New) Out-of-roundness tolerances apply to maximum and minimum diameters as measured with bar gage, caliper, or device measuring actual, maximum and minimum diameters.

- 5.7.1.2 In addition to API requirements, the wall thickness of each pipe shall be checked along the circumference at both ends and at the mid location of pipe body at 12 0' clock, 3 0' clock, 6 0' clock and 9 0' clock positions. The tolerances for wall thickness shall be as

given in Table 11 of this specification.

Table 11 of API Spec 5L stands replaced by Table 11 of this specification.

Wall thickness (mm)	Tolerances c, d (mm)
$t < 15.0 \text{ mm}$	+0.20 t
	-0.0t
$t \geq 15.0 \text{ mm}$	+3.0 mm
	-0.0 mm
a Deleted Deleted c The + ve tolerance for wall thickness does not apply to the weld area. d See 9.13.2 of API Spec 5L and as modified herein for additional restrictions.	

5.6.1.1 All pipes shall be supplied with length between 11.5 m and 12.5 m. However, pipe with length between 10.0 m and 11.5 m can also be accepted for a maximum of 5% of the ordered quantity. Overall length tolerance shall be (-) Zero and (+) One pipe length to complete the ordered quantity. Table 12 of API Spec 5L stands deleted.

5.6.1.2 The tolerances for straightness shall be as follows:

5.6.1.2.1 The total deviation from a straight line over the entire pipe length shall not exceed 12 mm, as shown in Figure I of API Spec 5L.

5.6.1.2.2 The local deviation from straight line in 1.5 m portion at each pipe end shall be  $\leq 3.2 \text{ mm}$ , as shown in Figure 2 of API Spec 5L.

## **5.7 Finish of Pipe Ends**

### **5.7.1 Plain ends**

#### 5.8.1.1

During removal of inside burrs at the pipe ends, care shall be taken not to remove excess metal and not to form an inside cavity on bevel. Removal of excess metal beyond the minimum wall thickness as indicated in clause 5.7.1.2 of this specification shall be a cause for re-bevelling. In case root face of bevel is less than that specified, the pipe ends shall be re-bevelled and rectification by filing or grinding shall not be done.

#### 5.8.1.2

### **Bevel Protectors**



## PROCUREMENT OF API 5L 3LPE COATED CS LINE PIPE



TENDER DOCUMENT NO:  
GSL/REPL/012/STPL

Date: 19/01/2023

Both pipe ends of each pipe shall be provided with metallic or high impact plastic bevel protectors as per Manufacturer's standard. Bevel protectors shall be of a design such that they can be re-used by coating applicator for providing on externally anti-corrosion coated pipes subsequent to coating of line pipe.

### 5.8.1.3

#### Reverse Bend Test

All pipes shall meet the minimum acceptance criteria for Reverse Bend Test as follows:

A specimen which fractures completely prior to the engagement of mandrel and specimen as specified in clause 6.2.4.3 (New) of this specification, or which reveals cracks or ruptures in the weld or heat affected zone longer than 4 mm shall be rejected. Cracks less than 6 mm long at the edges of the specimen shall not be cause for rejection. Dye penetrant testing shall be used to positively confirm cracks or openings.

## 6 INSPECTION

### 6.1 Types of Inspection and Inspection Documents

6.1.1 Inspection documents for PSL 2 pipes

6.1.1.1 Inspection certificate 3.2 in accordance with EN 10204 shall be issued for each dispatched pipe by Purchaser's authorized representative.

### 6.2 Specific Inspection

#### 6.2.1 Inspection frequency

6.2.1.1 For PSL 2 pipe, the inspection frequency shall be as given in Table 18 of this specification.

Table 18 of API Spec 5L stands replaced by Table 18 of this specification.

**Table 18 - Inspection frequency of pipe**

SI. no.	Type of inspection	Frequency of inspection
1	Heat analysis <sup>a</sup>	One analysis per heat of steel
2	Product analysis <sup>b</sup>	Two pipes per lot (maximum 100 pipes) per heat
3	Tensile testing of the pipe body	Two pipes per test unit of not more than 100 pipes per heat
4	Tensile testing of the longitudinal weld seam of pipe <sup>c</sup>	Two pipes per test unit of not more 100 pipes per heat
5	CVN impact testing of the pipe body	Once per test unit of not more than 50 pipes

6	CVN impact testing of the weld and HAZ of pipe	Once per test unit of not more than 50 pipes
7	Flattening test of pipe	As shown in Figure 6 a) of API Spec 5L
8	Reverse Bend Test (New)	Same as Figure 6 a) of API Spec 5L
9	Hardness testing	Any hard spot exceeding 50 mm (2.0 in) in any direction
10	Hydrostatic testing	Each pipe
11	Weighing of pipe	Each pipe shall be measured and recorded
12	Wall thickness measurement <sup>d</sup>	Each pipe
13	Pipe diameter and out-of-roundness d	Each pipe
14	Length	Each length of pipe shall be measured and recorded
15	Straightness d	Each pipe
16	Tolerances for the weld seam d a) Radial offset of coil edges b) Height of flash and c) Depth of groove after trimming of inside flash	Each pipe
17	Visual inspection	Each pipe
18	Metallographic testing (including Vicker's hardness test) of the longitudinal seam weld of pipe as defined in clause 6.2.5 of this specification	At least one finished pipe from each lot of 50 pipes per heat or at least once per operating shift (12 hrs max.) whichever is occurring more frequently and whenever changes of grade, diameter or wall thickness are made and whenever significant excursions from operating heat treatment conditions are encountered and at the beginning of the production of each combination of specified outside diameter and specified wall thickness.
19	Other dimensional testing	Random testing, with the details left to the discretion of the manufacturer
20	Non-destructive inspection	In accordance with Annex E of API Spec 5L and as modified herein
<p>a. Where the steel mill is not a part of an integrated pipe mill, heat analysis shall be reported by the Manufacturer prior to start of pipe production.</p> <p>b. Pipes selected shall be such that one at the beginning of the heat and one at the end of the heat are also represented.</p> <p>c. Pipe produced by each welding machine shall be tested at least once per week.</p> <p>d. Measurement shall be recorded at least 3 times per operating shift (12 hrs maximum).</p> <p>e. "Test unit" is as defined in clause 3.1.60 of API Spec 5L.</p>		

**6.2.1 Samples and test pieces for product analysis**



## PROCUREMENT OF API 5L 3LPE COATED CS LINE PIPE



TENDER DOCUMENT NO:  
GSL/REPL/012/STPL

Date: 19/01/2023

Samples shall be taken, and test pieces prepared, in accordance with ISO 14284 or ASTM E1806. Samples used for product analysis shall be taken from finished pipes only.

Samples for product analysis from coil may be used provided the traceability of samples is guaranteed.

### 6.2.2 Samples and test pieces for mechanical tests

#### 6.2.2.1 General

In addition to API Spec 5L requirements, samples and test pieces for various types of tests shall be taken from Figure 5 b) and Figure 6 a) of API Spec 5L

and Figure 10.2.4.9.1 & 10.2.5.3.2 of this specification, whichever is applicable, and as given in Table 20 of this specification.

Table 20 of API Spec 5L stands replaced by Table 20 of this specification.

Sample Location	Type of test	Number, Orientation and location of testpieces per sample <sup>a</sup>	
		Specified outside diameter, D mm (in)	
		< 219.1 mm (8.625 in)	≥219.1 mm (8.625 in)
Pipe body	Tensile	1 L90	1T180
	CVN	3T90	3T90
Seam Weld	Tensile	---	1W <sup>b</sup>
	CVN	3W and 3HAZ	3W and 3HAZ
	Hardness	1W (As shown in figure 10.2.5.3 of this specification)	
Pipe body and weld	Flattening	As shown in figure 6 a) of API Spec 5L	
	Reverse Bend	As shown in figure 10.2.4.9.1 of this specification	

a. See figure 5 (b) of API Spec 5L for an explanation of the symbols used to designate orientation and location.

b. Test specimen shall be tested for ultimate tensile strength only.

#### 6.2.1.2 Test pieces for the tensile test

Rectangular test pieces, representing the full wall thickness of the pipe, shall be taken in accordance with ASTM A370 and as shown in Figure 5 b) of API Spec 5L.



## PROCUREMENT OF API 5L 3LPE COATED CS LINE PIPE



TENDER DOCUMENT NO:  
GSL/REPL/012/STPL

Date: 19/01/2023

Longitudinal tensile tests for pipe body with specified outside diameter,  $D < 219.1$  mm (8.625 inch) shall be carried out on a strip specimen representing full wall thickness of the pipe prepared according to ASTM A370.

Transverse tensile test for pipe body with specified outside diameter,  $D \geq 219.1$  mm (8.625 inch) shall be carried out on flattened rectangular test pieces.

For tensile test piece, both inside and outside flash of weld in excess of pipe wall thickness shall be removed from the test piece either by grinding or machining.

### 6.2.1.3 Test pieces for the CVN impact test

In addition to the API Spec 5L requirements, following shall also be applicable:

The test pieces shall be prepared in accordance with ASTM A370. Non-flattened test pieces shall be used. The axis of the notch shall be perpendicular to the pipe surface.

Charpy V-notch impact testing shall be performed on full-sized test pieces. However, if preparation of full size test piece is not possible, then standard sub-sized test pieces shall be prepared as per ASTM A370.

### 6.2.3.4 Lower pipe sizes wherein preparation of transverse sub-sized specimen is not possible, CVN impact testing shall be carried out on longitudinal test specimen [see Note 'a' of Table 8 of this specification] Test pieces for flattening test

The test pieces shall be prepared in accordance with ISO 8492. The length of each test piece shall be  $\geq 60$  mm.

Minor surface imperfections may be removed by grinding.

### 6.2.3.5 Test pieces for Macro graphic and metallographic tests

(New) Test piece for metallographic testing shall be taken transverse to the longitudinal weld seam as indicated in Figure 10.2.5.3 of this specification. The test piece shall be suitably ground, polished and etched to reveal the macro-structure.

### 6.2.3.6 Test pieces for Reverse bend test

(New) Ring specimen of width between 100 mm to 115 mm shall be taken from the pipe. Reverse bend test shall be carried out as per clause 6.2.4.3 (New) of this specification.

## 6.2.4 Test methods

### 6.2.4.1 CVN impact test

The Charpy test shall be carried out in accordance with ASTM A370.

### 6.2.4.2 Flattening test

In addition to the API Spec 5L requirements, following shall also be applicable: The flattening test shall be carried out in accordance with ISO 8492.

**6.2.4.3 Reverse bend test**

(New) The mandrel shall be plunged into the test piece prepared in accordance with clause 6.2.3.6 (New) of this specification, with the weld in contact with the mandrel, to such a depth that the angle of engagement between mandrel and specimen reaches 60° as shown in figure 10.2.4.9.1 of this specification. If the combination of diameter & wall thickness of pipe and radius of mandrel is such that the angle of engagement cannot reach 60°, then the mandrel shall be plunged into the specimen until opposite walls of the specimen meet.

**Selection of Mandrel**

The reverse bend test shall be carried out with a mandrel, whose radius (R), or width (A) shall be calculated for any combination of diameter, wall thickness and grade with the following formula:

$$A = 2R = \frac{1.4(D - t)t}{e(D - 2t) - 1.4t} - t$$

Where,

- D - Specified outside diameter of pipe, mmt
- t - Specified wall thickness of pipe, mm
- 1.4 - Peaking factor

e - Strain Minimum value of 'e' shall be as per Table 23 of API Spec 5L reproduced as below:

**Table 23 — Strain Values for Guided-bend Test**

Pipe grade	Strain value 'e'
Gr. B	0.1375
X42	0.1375
X46	0.1325
X52	0.1250
X56	0.1175
X60	0.1125
X65	0.1100
X70	0.1025

**6.2.5 Macro graphic and metallographic tests**

6.2.5.1 The test piece shall be visually examined using a minimum 40X magnification to provide evidence that heat treatment of weld zone is adequate and there is no untampered martensite or detrimental oxides from the welding process present along the weld seam. The metallographic examination shall be documented on micrographs (at 10X to 20X magnification). In case imperfections or defects are observed, it will become a cause for re- evaluation of welding parameters and heat treatment as deemed necessary by Purchaser's Representative.

Vickers hardness tests shall be carried out on each test piece taken for metallographic examination in accordance with ISO 6507-1, at locations indicated in Fig. 10.2.5.3 of this specification. Indentation in the HAZ shall start as close to the fusion line as possible. The resulting Vickers hardness value at any point shall not exceed 248HV<sub>10</sub>. The maximum difference in hardness between the base metal and any reading taken on the weld or heat affected zone shall be less than 80HV<sub>10</sub>. Modalities of retest shall be in accordance with clause 10.2.12.7 of API Spec 5L.

**6.2.6 Hydrostatic test**

6.2.6.1 Test pressure shall be held for a minimum period of 15 seconds for all sizes and grades of pipes.

6.2.6.2 In addition to the requirements of API Spec 5L, following shall also be applicable:

The pressure gauge used for hydrostatic testing shall have a minimum range of 1.5 times and maximum range of 4 times the test pressure. The test-pressure measuring device shall be calibrated by means of a dead-weight tester only. The test configuration shall permit bleeding of trapped air prior to pressurization of the pipe.

6.2.6.3 The test pressure for all sizes and grades of pipe shall be such that hoop stress (fibre stress) generated is at least 95% of SMYS, computed based on the Equation (6) indicated in clause 10.2.6.5 of API Spec 5L. Table 26 of API Spec 5L stands deleted.

**6.2.7 Visual inspection**

6.2.7.1 Each pipe shall be visually examined for entire external surface and internal surface to the extent feasible and shall be free of defects in finished condition. Visual examination shall be carried out in a sufficiently illuminated area; minimum 1000 lx. If required additional lights shall be used to obtain good contrast and relief effect between imperfections and backgrounds.

**6.2.8 Dimensional testing**

6.2.8.1 Diameter measurements shall be made with a circumferential tape only.

6.2.8.2 The measuring equipment requiring calibration or verification under the provisions of



## PROCUREMENT OF API 5L 3LPE COATED CS LINE PIPE



TENDER DOCUMENT NO:  
GSL/REPL/012/STPL

Date: 19/01/2023

API Spec 5L shall be calibrated with manual instruments at least once per operating shift (12 hours' maximum). Such calibration records shall be furnished to Purchaser's Representative on request.

### 6.2.9 Non-destructive inspection

Non-destructive inspection shall be performed in accordance with Annex E of API Spec 5L and as modified herein.

### 6.2.10 Reprocessing

This clause of API Spec 5L stands cancelled.

### 6.2.11 Retesting

#### 6.2.11.1 Recheck analyses

Modalities of recheck analysis shall be as per API Spec 5L as applicable to the lot being tested (see Table 18 of this specification). However, during individual testing, each pipe shall be fully analysed to meet the requirements of Table 5 of this specification.

#### 6.2.11.2 Reverse bend retests

(New) Reverse bend retest provisions shall be same as specified for flattening retests in clause 10.2.12.3 of API Spec 5L.

## 7 MARKING

### 7.1 GENERAL

7.1.1 Pipe manufactured in accordance with this specification shall be marked by the manufacturer as per the requirements of API Spec 5L and as modified herein. Marking shall be in English language and International System (SI) of Units.

7.1.2 (New) The marking of finished line pipe should also contain the Purchase Order No, Item No, Pipe No, Heat No, coated pipe No, Inspection mark by TPI, Diameter of pipe and wall thickness (to be marked in white color).

### 7.2 Pipe markings

7.2.1 (New) Actual length in meters and actual pipe weight in kg shall be marked

7.2.3 (New) Paint used for stencil marking shall withstand a temperature (New) up to 250°C expected to be experienced during further external anti-corrosion coating operations of line pipe by coating applicator. The pipe number shall be placed by cold rolling or low stress dot marking or vibrio-etching on the outside surface of the pipe at an approximate distance of 50 mm from both ends. In case of non-availability of either cold rolling or low stress dot marking facility in



## PROCUREMENT OF API 5L 3LPE COATED CS LINE PIPE



TENDER DOCUMENT NO:  
GSL/REPL/012/STPL

Date: 19/01/2023

pipe mill, an alternative marking scheme of a permanent nature may be proposed by the Manufacturer.

- 7.2.4 A Colour code band shall be marked on inside surface of finished pipe for identification of pipes of same diameter but different wall thickness, as indicated in the Purchase Order.

The Colour code band shall be 50 mm wide and shall be marked at a distance of 150mm from the pipe ends.

- 7.2.5 (New) Barcode identification system shall be provided by the pipe supplies, which shall have a life of 5 years over and above the conventional marking as per API 5L. The Manufacturer shall propose marking system to clearly identify the type of pipes.

## 8 COATINGS AND THREAD PROTECTORS

- 8.1.1 Unless otherwise specified in the Purchase Order, the pipes shall be delivered bare, free of any trace of oil, stain, grease and paint. Varnish coating shall be applied on the marking area.

Bevels shall be free of any coating.

## 9 RETENTION OF RECORDS

In addition to the records indicated in API Spec 5L, the Manufacturer shall retain the records of all additional tests and calibration records mentioned in this specification including the hard copy records of ultrasonic testing carried out on pipe/coil as well as pipe ends.

## 10 PRODUCTION REPORT

The Manufacturer shall provide one electronic copy and six hard copies of production report in English language indicating at least the following for each pipe. International system of units (SI) shall be adopted.

- Pipe number
- Heat number from which pipe is produced
- Pipe length and weight

Pipe grade The Manufacturer shall provide one electronic copy and six hard copies of acceptance certificates which shall include the results of all tests required as per this specification and performed on delivered material giving details of, but not limited to, the following:

- All test certificates as per clause 10.1.3 of API Spec 5L and as modified herein.



## PROCUREMENT OF API 5L 3LPE COATED CS LINE PIPE



TENDER DOCUMENT NO:  
GSL/REPL/012/STPL

Date: 19/01/2023

- Records of qualification of welders and procedures for repair welding.
- Certified reports of dimensional inspection, surface imperfections & defects.
- Data on test failures, rejected heats/lots, etc.
- All other reports and results required as per this specification.

The certificates shall be valid only when signed by the Purchaser's Representative. Only those pipes, which have been certified by the Purchaser's Representative, shall be dispatched from the pipe mill.

In the event of small quantities of pipes supplied against this specification, the production report may consist of only test certificates required as per clause 10.1.3 of API Spec 5L and as modified herein and other test reports/results required as per this specification.

### 11 INSPECTION OF FIELD TESTS & WARRANTY

Purchaser shall be reimbursed by Manufacturer for any pipe furnished on this order that fails under field hydrostatic test if such failure is caused by a material/manufacturing defect in the pipe. The reimbursement cost shall include pipe, labour and equipment rental for finding, excavating, cutting out and installation of replaced pipe in position. The field hydrostatic test pressure will not exceed that value which will cause a calculated hoop stress equivalent to 95 percent of specified minimum yield strength.

In case Manufacturer so desires, he will be advised at least two weeks in advance so that his Representative may witness the hydrostatic test in field, however, the testing and leak (if any) finding and repair operation shall not be postponed because of absence of the Manufacturer's Representative. **Annex B**

#### Manufacturing Procedure Qualification for PSL 2 Pipe

##### B.1 INTRODUCTION

- B.1.1 This annex specifies additional provisions that apply for the PSL 2 pipes ordered as per this specification.
- B.1.2 Two lengths each of completely finished pipes from two different heats (i.e. a total of four pipe lengths) shall be selected at random for testing as per clause B.5.1 of this specification to verify that the manufacturing procedure results in the quality of pipes which are in complete compliance with this specification. The pipes thus tested shall be considered to be the test pipes required per heat or per lot as per relevant clauses of this specification.

These manufacturing procedure qualification tests (MPQT) shall be repeated upon any change in the manufacturing procedure as deemed necessary by Purchaser's Representative. The manufacturing procedure qualification tests shall be carried out on pipes for each wall thickness, each diameter and each grade of steel.



## PROCUREMENT OF API 5L 3LPE COATED CS LINE PIPE



TENDER DOCUMENT NO:  
GSL/REPL/012/STPL

Date: 19/01/2023

- B.1.3 Verification of the manufacturing procedure shall be by qualification in accordance with clause B.3, B.4 and B.5 of API Spec 5L and as modified herein.

Note: In the event of small quantities of pipes (i.e. less than 50 numbers) ordered against this specification, like those for bends and other similar applications, as specifically called out in the Purchase Order, the manufacturing procedure qualification test as per clause B.5.1 of this specification shall not be carried out. Pipes in such case shall be accepted based on regular production tests.

### **B.3 CHARACTERISTICS OF THE MANUFACTURING PROCEDURE SPECIFICATION**

Before pipe production commences, Manufacturing Procedure Specification (MPS) for manufacturing of pipes and Statistical process control charts shall be prepared by pipe manufacturer (including all information as per clause B.3 a), b) and e) of API Spec 5L) and submitted for approval of the Purchaser.

### **B.5 MANUFACTURING PROCEDURE QUALIFICATION TESTS (MPQT)**

- B.5.1 For the qualification of the manufacturing procedure, all tests & inspections specified in Table 18 and clause B.5.2 of this specification shall be conducted on all the pipes selected for testing as per clause B.1.2 of this specification.

- B.5.2 The Manufacturer shall submit to Purchaser a report giving the results of all tests mentioned below. The report shall be agreed and signed by Purchaser's Representative, prior to start of regular production.

The various tests to be conducted on each pipe shall be as follows. The test method and acceptance values shall be as per this specification unless specified differently in this Annex.

**a. Visual Examination**

- b. All pipes shall be examined visually for dimensional tolerances and apparent surface defects.  
**Ultrasonic Examination**

The weld seam of all pipes shall be examined ultrasonically by automatic ultrasonic equipment.

**c. Mechanical Properties**

The mechanical properties of all pipes shall be tested and shall meet the requirements of this specification. Purchaser's Representative will select the places in pipe from where the test pieces shall be extracted.

The following tests shall be conducted:



## PROCUREMENT OF API 5L 3LPE COATED CS LINE PIPE



TENDER DOCUMENT NO:  
GSL/REPL/012/STPL

**Date: 19/01/2023**

### i. Flattening test

Two (2) flattening test pieces shall be extracted; one test piece shall be tested with weld at 0° and other at 90°.

### ii. Tensile test

Tensile tests shall be conducted on:

For pipe with specified outside diameter,  $D < 219.1$  mm (8.625 inch):

- Two (2) longitudinal test pieces from base metal

For pipe with specified outside diameter,  $D \geq 219.1$  mm (8.625 inch):

- Two (2) transverse test pieces from base metal
- Two (2) transverse test pieces from the longitudinal weld seam

### iii. Metallographic tests

Six (6) weld cross-section test pieces, three (3) from each end of pipe weld seam shall be taken for metallographic examination. Two of these shall be tested for hardness at room temperature after etching, one from each end of pipe.

### iv. CVN impact testing



CVN impact test shall be performed on test pieces extracted as follows:

- Five (5) sets of three (3) transverse test pieces each from base metal
- One (1) set of three (3) transverse test pieces with weld in middle
- One (1) set of three (3) transverse test pieces with HAZ in middle

The minimum average (set of three test pieces) absorbed energy value (KvT) at the test temperature specified in clause 5.5 and Table 8 of this specification shall be complied with for test pieces extracted from base metal, weld and HAZ.

### v. Fracture toughness testing

Four (4) sets of CVN base metal test pieces shall be tested at, - 40°C, -30°C, -20°C, - 10°C, 0°C, +10°C and + 20° C for shear area and absorbed energy to produce full transition curve. The minimum average (set of three test pieces) shear fracture area at the test temperature specified in clause 5.5 of this specification shall be complied with. For other temperatures, the value shall be for information only.

	<b>PROCUREMENT OF API 5L 3LPE COATED CS LINE PIPE</b>	
TENDER DOCUMENT NO: GSL/REPL/012/STPL		<b>Date: 19/01/2023</b>

## Annex C

### Treatment of surface imperfections and defects

#### **C.1 TREATMENT OF SURFACE IMPERFECTIONS**

Surface imperfection not classified as defect as per this specification shall be cosmetically dressed-out by grinding.

#### **C.2 TREATMENT OF DRESSABLE SURFACE DEFECTS**

C.2.3 Complete removal of defects shall be verified by local visual inspection and by suitable non-destructive inspection. To be acceptable, the wall thickness in the ground area shall be in accordance with clause 5.7.1.2 of this specification. **Annex E**

### Non-destructive inspection for Pipe

The Purchaser reserves the right to depute its Representative(s) to perform inspection and witness tests in all phases of manufacturing and testing starting from steelmaking to finished line pipe ready for shipment. Manufacturer shall comply with the provisions regarding inspection notice, plant access, compliance and rejection mentioned in the Annex Q (New) of this specification. The Manufacturer shall give the Purchaser reasonable notice of the starting date of normal production and the work schedule. Any action or omission on part of Purchaser's Representative shall not relieve the Manufacturer of his responsibility and obligation to supply material in strict accordance with this specification.

#### **E.1 QUALIFICATION OF PERSONNEL**

E.1.1 All personnel performing NDT activities shall be qualified in the technique applied, in accordance with latest edition of ISO 9712, ISO 11484 or ASNT No. ASNT-TC-1A or equivalent

All NDT shall be performed in accordance with written procedures. These procedures shall have prior approval of the Purchaser.

##### **Inspector Qualification**

Acceptable qualification for NDT inspectors shall be as specified below:

(i) For UT

For UT, at least one Level III qualified inspector shall be available to the mill for overall supervision. Level III inspectors shall be ASNT Level III or ACCP Professional Level III and certified in applicable method.

A level II inspector is required for shift supervision, manual weld inspection and calibration of all systems (both manual and automated).



## PROCUREMENT OF API 5L 3LPE COATED CS LINE PIPE



TENDER DOCUMENT NO:  
GSL/REPL/012/STPL

Date: 19/01/2023

(ii) For all other NDT methods

Evaluation of indications Level II & Level III inspector

### **E.3 METHODS OF INSPECTION**

#### **E.3.1 General**

E.3.1.1 The electric weld of the pipe shall be inspected by ultrasonic methods (Refer Table E.1 of API Spec 5L) for full length (100%) for the entire thickness, using automatic ultrasonic equipment in accordance with clause E.5 of API Spec 5L and as modified in this specification.

E.3.1.3 Location of NDT equipment in the manufacturer's facility shall be such that final inspection of weld seam of pipe shall be performed after hydrostatic testing.

#### **E.3.2 Pipe End Inspection - Welded Pipe**

Pipe ends including weld at the pipe ends not covered by automatic ultrasonic equipment shall be inspected by manual ultrasonic equipment with same sensitivity and capability as automatic equipment, or, such non-inspected pipe end shall be cut-off. Records in accordance with E.5.4 of API Spec 5L shall be maintained.

E.3.2.3 Ultrasonic inspection in accordance with the method described in ISO 10893-8 shall be used to verify that the 50 mm (2.0 in) wide zone at each pipe end is free of any laminar imperfections in the circumferential direction.

E.3.2.4

(New) Bevel face of each pipe end shall be magnetic particle inspected for the detection of laminar imperfections in accordance with ISO 10893-5

### **E.5 ULTRASONIC AND ELECTROMAGNETIC INSPECTION**

E.5.1.1 In addition to the API Spec 5L requirements, all automatic ultrasonic equipment shall have an alarm device, which continuously monitors the effectiveness of the coupling. The equipment for the automatic inspection shall allow the localization of both longitudinal and transverse defects corresponding to the signals exceeding the acceptance limits of the reference standard. The equipment shall be fitted with a paint spray or automatic marking device and alarm device for areas giving unacceptable ultrasonic indications. All ultrasonic testing equipment shall be provided with recording device. In addition, an automatic weld tracking system shall be provided for correct positioning of the probes with respect to weld centre.

#### **E.5.2 Ultrasonic and electromagnetic inspection reference standards**

E.5.2.1 The reference standard (calibration pipe) shall have the same specified diameter and wall

thickness as specified for the production pipe being inspected.

E.5.2.2 Reference standards shall be of sufficient length to permit calibration of ultrasonic inspection equipment at the speed to be used in normal production.

The reference standard (calibration pipe) shall also be of the same material, type and have the same surface finish and heat treatment as the pipe being inspected.

**E.5.2.3 Reference standards**

**E.5.2.3.1 Reference standards for pipe weld UT:**

(New) Reference standard shall contain as reference indicators i.e. machined notches as given in Table E.7 of this specification

Table E.7 of API Spec 5L stands replaced by Table E.7 of this specification.

**Table E.7 — Reference Indicators**

Item	Reference indicators		
	Number of notches and orientation <sup>a</sup>		Notch Type <sup>b</sup>
	OD	ID	
Weld Seam	1L	1L	N10

<sup>a</sup> The symbol indicates the orientation of the notch i.e. L = Longitudinal.  
Reference indicators shall be located as per Figure E.I of this specification.  
<sup>b</sup> Dimensions of Notch type N10 shall be 0.1 t x 50 mm x 1 mm (Depth x maximum Length x maximum width), where, 't' is the specified wall thickness. The depth tolerance is ± 15% of the specified notch depth or ± 0.05 mm, whichever is greater.

**E.5.2.3.2 Reference standards for coil/ pipe body UT:**

(New) Reference standard for the ultrasonic inspection of coil or pipe body (except the coil edges/pipe ends) shall contain continuous machined notch of following dimension:

a) width, w : 8 mm, with a tolerance +0.8/ - 0.0 mm

b) depth, d : 0.25 t < d < 0.5 t, where 't' is the specified wall thickness

Reference standard for the ultrasonic inspection of coil edges (area adjoining weld seam)/ pipe ends shall have 6.4 mm (1/4 inch) diameter FBH of a depth 0.5 t, where 't' is the specified wall thickness.

**E.5.3 Instrument standardization**



## PROCUREMENT OF API 5L 3LPE COATED CS LINE PIPE



TENDER DOCUMENT NO:  
GSL/REPL/012/STPL

Date: 19/01/2023

E.5.3.2 The instrument shall be calibrated with appropriate reference standard (refer E.5.2 of API Spec 5L and as modified herein) at following intervals:

- Once at the beginning of each operating shift (12 hours' maximum).
- Once in between of each operating shift i.e., 3 hrs to 4 hrs after the first
- Every time there is change in probes or working condition of the UT machine.
- Every time the running of the system gives rise to doubts on its efficiency.

If during the above calibration verification, it is found that the equipment has not functioned satisfactorily in the opinion of the Purchaser's Representative, all the pipes or coils already inspected after the previous verification shall be inspected again at Manufacturer's cost.

### **E.5.5 Acceptance Limits**

E.5.5.2 For ultrasonic inspection of pipe/coil, any imperfection that produces an imperfection greater than the acceptable limits shall be treated as following:

- a) Locations showing indications above the acceptance limits during automatic ultrasonic inspection may be re-examined by manual ultrasonic method. If no defects are located during re-examination, the original findings may be ignored. Additional scanning may be requested by Purchaser's Representative to check questionable areas.

### **E.5.6 Disposition of defects found by Ultrasonic and electromagnetic inspection**

Disposition of any imperfection in pipe/coil that produces an indication greater than the acceptable limits as specified in Table E.9 (New) of this specification shall be classified as defect and shall be given disposition as specified in (e) or (f) of E.10 of API Spec 5L.

E.7.2 **RESIDUAL MAGNETISM** The longitudinal magnetic field shall be measured on all sizes of pipes. Measurement on pipe in stack shall not be considered valid. Such measurements shall be taken on the root face or square cut face of finished plain-end pipes.

E.7.3 Measurements shall be made using Hall - effect gaussmeter only.

E.7.4 Measurements shall be made on each end of a pipe for 5% of the pipes produced but at least once per 4 hr per operating shift (12 hrs maximum).

E.7.6 Four readings shall be taken approximately 90° apart around the circumference of each end of the pipe. The average of the four readings shall not exceed 2.0 mT (20 gauss) and no single reading shall exceed 2.5 mT (25 gauss). All residual magnetism measurements



## PROCUREMENT OF API 5L 3LPE COATED CS LINE PIPE



TENDER DOCUMENT NO:  
GSL/REPL/012/STPL

Date: 19/01/2023

shall be recorded.

### **E.7 LAMINAR IMPERFECTIONS IN THE PIPE BODY OF EW, SAW AND COWPIPE**

E.7.1 The coil, except the longitudinal coil edges (area adjoining weld seam), shall be ultrasonically tested for laminations using an oscillating or straight running pattern of probes in accordance with ISO 10893-9 amended as follows:

The distance between adjacent scanning tracks shall be sufficiently small to ensure detection of minimum allowed imperfection size. The minimum coverage during automatic ultrasonic inspection shall be  $\geq 20\%$  of the coil surface uniformly spread over the area.

Acceptance limit for laminar imperfection in the coil, except the longitudinal edges, shall be as per Table E.9 (New) of this specification. Disposition of defects shall be as per clause E.5.6 of this specification.

Table 3 of ISO 10893-9 stands replaced by Table E.9 (New) of this specification.

### **E.9. LAMINAR IMPERFECTIONS ALONG THE STRIP/ PLATE EDGES OR PIPEWELD SEAM OF EW, SAW AND COW PIPES**

The longitudinal edges of the coil (area adjoining weld seam) shall be 100% ultrasonically inspected in accordance with ISO 10893-9 amended as follows:

UT shall be performed over 25 mm wide zone along each side of the trimmed longitudinal edges of the coil.

Acceptance limit for laminar imperfection in the longitudinal edges of the coil shall be as per Table E.9 (New) of this specification. Disposition of defects shall be as per clause E.5.6 of this specification.

Table 2 of ISO 10893-9 stands replaced by Table E.9 (New) of this specification

**Table E.9 - Acceptance criteria for laminar imperfection in coil/ pipe body (New)**

Location	Maximum individual imperfection		Minimum imperfection size considered			Maximum population density <sup>a</sup>
	Area mm <sup>2</sup>	Length <sup>b</sup> mm	Area mm <sup>2</sup>	Length <sup>b</sup> mm	Width <sup>c</sup> mm	
Coil, except the longitudinal edges	1000	100 <sup>d</sup>	300	35	8	10 (per 1.0 m x 1.0m)



# PROCUREMENT OF API 5L 3LPE COATED CS LINE PIPE



TENDER DOCUMENT NO:  
GSL/REPL/012/STPL

Date: 19/01/2023

Longitudinal edges of the coil	500	40	----	20	--	4 (per 1.0 m length)
<p>a Number of imperfections of size smaller than the maximum imperfection size greater than the minimum imperfection size.</p> <p>b Length is the dimension at right angles to the scan track. c Width is the dimension parallel to the scan track.</p> <p>d Any planar imperfection which is not parallel to the coil surface is not acceptable.</p> <p>e For an imperfection to be larger than the minimum imperfection size, the mini area, minimum length and minimum width given for the coil/ pipe body, all have t exceeded.</p>						

## E.10 DISPOSITION OF PIPES CONTAINING DEFECTS

a) The repaired area shall be 100% rechecked by magnetic particle or ultrasonic inspection to ensure complete removal of defects. However for repair of cosmetic type of defects, MPI may not be conducted if so directed by Purchaser's Representative on case to case basis. The pipes having a thickness less than the minimum allowed in accordance with this specification, after repair by grinding shall be treated for disposition in accordance with (c) or (d) of clause E.10 of API Spec 5L.

## E.11 ROTARY ULTRASONIC INSPECTION OF PIPE (ALTERNATIVE METHOD)

(New) As an alternative, full pipe may be ultrasonically inspected after welding of longitudinal seam by rotary ultrasonic testing method (pipe in rotating condition) in accordance with ISO 10893-8 amended as follows:

The coverage area during ultrasonic inspection shall be 100 % of the pipe body including weld seam, sides of the weld seam and pipe ends.

The reference standard for the weld seam as per clause E.5.2.3.1 and Table E.7 of this specification shall be used for the rotary ultrasonic testing.

If the manufacturer opts for rotary ultrasonic testing of full pipe in accordance with this clause, then, the requirement for ultrasonic inspection as per clause E.3.1.1, E.3.2.3, E.8 and E.9 of API Spec 5L and as modified herein shall not be applicable.



## PROCUREMENT OF API 5L 3LPE COATED CS LINE PIPE



TENDER DOCUMENT NO:  
GSL/REPL/012/STPL

Date: 19/01/2023

### Annex Q (New)

#### Purchaser Inspection

##### Q.1 INSPECTION NOTICE

Advance notice shall be given by the manufacturer prior to the start of production to the purchaser to inspect/witness the manufacturing activities including tests.

##### Q.2 PLANT ACCESS

The inspector representing the purchaser shall have unrestricted access, at all times while work of the contract of the purchaser is being performed, to all parts of the manufacturer's works that will concern the manufacture of the pipe ordered. The manufacturer shall afford the inspector all reasonable facilities to satisfy the inspector that the pipe is being manufactured in accordance with this specification. All inspections should be made at the place of manufacture prior to shipment, unless otherwise specified on the purchase order, and shall be so conducted as not to interfere unnecessarily with the operation of the works.

##### Q.3 COMPLIANCE

The manufacturer is responsible for complying with all of the provisions of this specification. The purchaser may make any investigation necessary to be satisfied of compliance by the manufacturer and any reject any material that does not comply with this specification.

##### Q.4 REJECTION

If the Purchaser Representative rejects pipes repeatedly for any recurring cause, this shall be adequate reason to refuse final inspection of subsequent pipes until the cause has been investigated and corrective action taken by the Manufacturer.

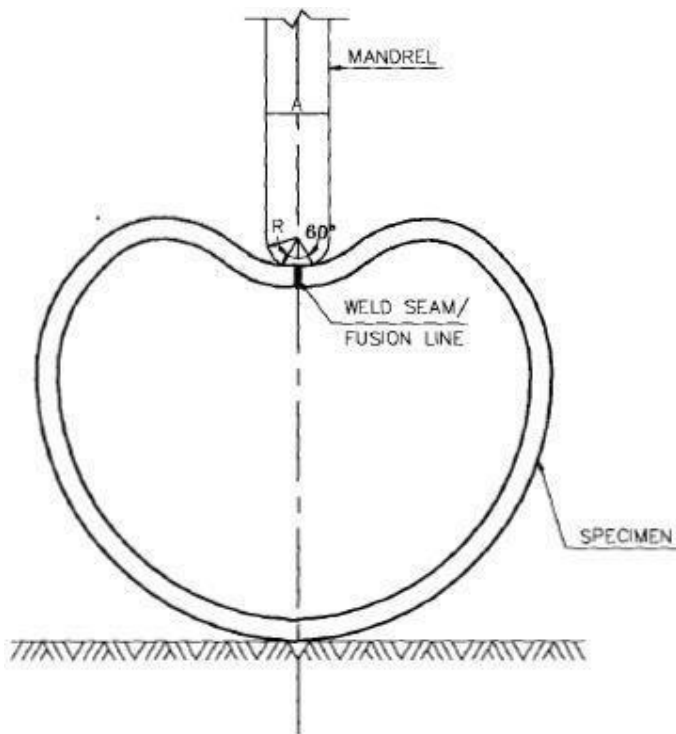

**REVERSE BEND TEST**

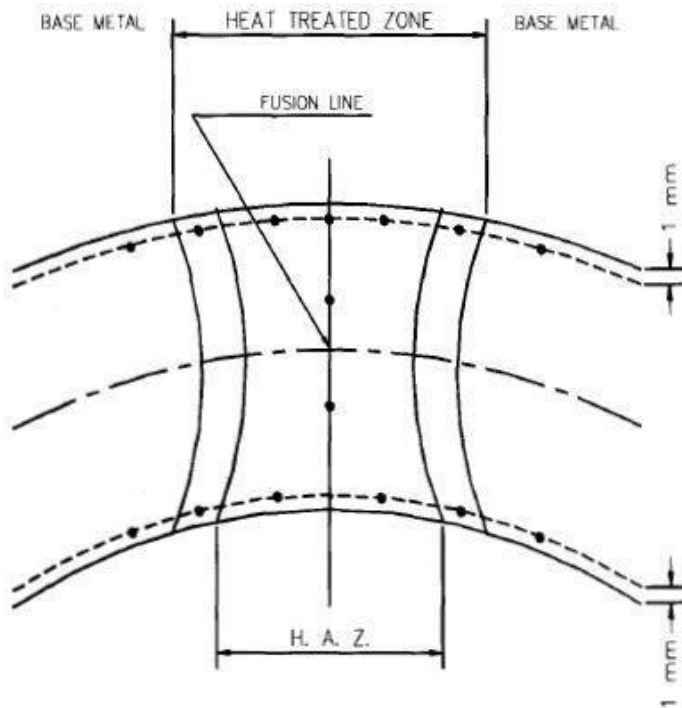

● LOCATIONS WHERE HARDNESS MEASUREMENT TO BE CARRIED OUT.  
H.A.Z. HEAT AFFECTED ZONE

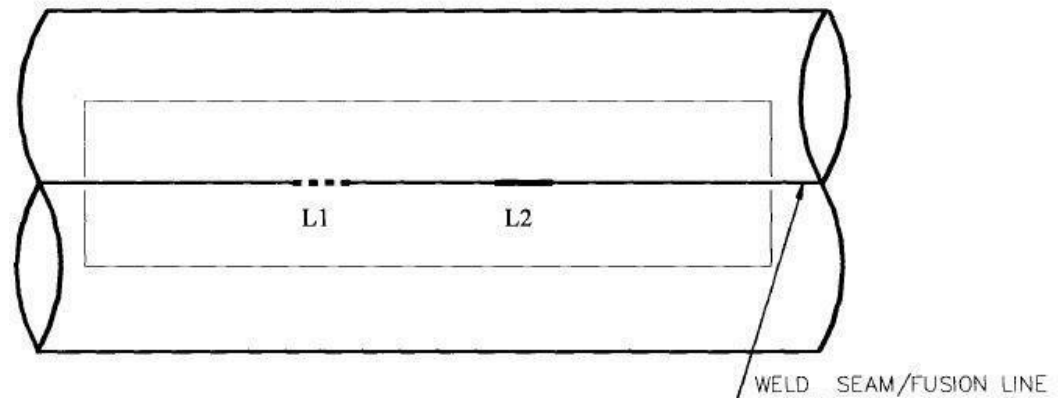
**METALLOGRAPHIC SPECIMEN AND LOCATIONS FOR HARDNESS MEASUREMENT**

- L1 - Longitudinal inside notch (N10) at weld line  
L2 - Longitudinal outside notch (N10) at weld line

**REFERENCE STANDARD FOR UT OF LONGITUDINAL WELD SEAM**



**PROCUREMENT OF API 5L 3LPE COATED CS LINE PIPE**



TENDER DOCUMENT NO:  
GSL/REPL/012/STPL

**Date: 19/01/2023**

**STANDARD SPECIFICATION FOR SEAMLESS (SMLS)  
LINE PIPE**



## PROCUREMENT OF API 5L 3LPE COATED CS LINE PIPE



TENDER DOCUMENT NO:  
GSL/REPL/012/STPL

**Date: 19/01/2023**

### CONTENTS

1. SCOPE
2. NORMATIVE REFERENCES<sup>3</sup>
3. PIPE GRADE, STEEL GRADE AND DELIVERY CONDITION
4. MANUFACTURING
5. ACCEPTANCE CRITERIA
6. INSPECTION
7. MARKING
8. COATINGS AND THREAD PROTECTORS
9. RETENTION OF RECORDS
10. PRODUCTION REPORT
11. INSPECTION OF FIELD TESTS & WARRANTY



## PROCUREMENT OF API 5L 3LPE COATED CS LINE PIPE



TENDER DOCUMENT NO:  
GSL/REPL/012/STPL

Date: 19/01/2023

### 1. SCOPE

This specification establishes the minimum requirements for the manufacture of seamless steel line pipe for onshore service in accordance with the requirements of API (American Petroleum Institute) Specification 5L, Forty- Sixth Edition, April 2018 and makes restrictive amendments to API Specification 5L. Unless modified and/or deleted by this specification, the requirements of API Specification 5L shall remain applicable.

The sections, paragraphs and annexes contained herein have the same numbering as that of API Spec 5L in order to facilitate reference. Additional requirements, which are not specified in API Spec 5L, have also been numbered and marked as "(New)".

The coverage by this specification is limited to line pipe to be used in onshore pipelines transporting non-sour hydrocarbons in liquid or gaseous phase. The product specification level for line pipe to be supplied as per this specification shall be "PSL 2".

The Manufacturer shall have a valid license to use API Monogram in accordance with the requirements of Specification 5L, Forty-Sixth Edition, April 2018 for line pipe as Product Specification Level PSL 2.

#### 1.1 Pipe Size

This Specification shall be applied to line pipe of size 4.5" OD thru 20" OD (both sizes included).

### 2. NORMATIVE REFERENCES

The latest edition (edition enforce at the time of issue of enquiry) of following additional references are included in this specification:

ASTM

ASTM E112: Standard Test Methods for Determining Average Grain size

### 3. PIPE GRADE, STEEL GRADE AND DELIVERY CONDITION

#### 3.1 PIPE GRADE AND STEEL GRADE

3.1.2 Line pipe supplied to this specification shall conform to Product Specification Level 2 (PSL2) as given in Table 1 of this specification and consists of an alpha or alphanumeric designation that identifies the strength level of the pipe. The steel name (designating a steel grade), linked to the chemical composition of the steel, additionally includes a suffix that consists of a single letter (N or Q) that identifies the delivery condition as per Table 3 of this specification.

Table 1 of API Spec 5L stands replaced by Table 1 of this specification.

**Table 1- Pipe grades, steel grades and acceptable delivery conditions**



# PROCUREMENT OF API 5L 3LPE COATED CS LINE PIPE



TENDER DOCUMENT NO:  
GSL/REPL/012/STPL

Date: 19/01/2023

PSL	Delivery Condition	Pipe grade! steel grade <sup>a,b</sup>
PSL -2	Normalized	BN, X42N, X46N, X52N
	Quenched and tempered	BQ, X42Q, X46Q, X52Q, X56Q, X60Q, X65Q & X70Q
	a Deleted b The suffix (N or Q) for PSL 2 grades belongs to steel grade	

### 3.2 DELIVERY CONDITION

3.2.2 The delivery condition for starting material shall be in accordance with Table 1 of this specification.

## 4. MANUFACTURING

### 4.1 PROCESS OF MANUFACTURE

Pipe furnished to this specification shall be manufactured in accordance with the applicable requirements and limitations given in Table 2 of API Spec 5L and Table 3 of this specification.

Table 3 of API Spec 5L stands replaced by Table 3 of this specification.

**Table 3 - Acceptable manufacturing routes for PSL 2 pipe**

Type of Pipe	Starting Material	Pipe forming	Pipe heat treatment	Delivery condition
MLS	Ingots, Bloom or billet	Normalising forming	None	N
		Hot forming	Normalising or Quenched & Tempered	N or Q
		Hot forming and cold finishing		N or Q

### 4.2 STARTING MATERIAL

4.2.2 Line pipe furnished to this specification shall be made from steel produced in basic oxygen or electric arc furnace. Steel shall be made by continuous casting only.

4.2.1 The steel used for manufacture of pipe shall be fully killed and fine grained with ASTM grain size number 7 or finer as per ASTM E 112.

### 4.3 COLD SIZING AND COLD EXPANSION

4.3.1 Pipes furnished to this specification shall be non-expanded.

### 4.4 JOINTERS

4.4.1 Jointers on pipes are not permitted.

## 5. ACCEPTANCE CRITERIA

### 5.2 CHEMICAL COMPOSITION

5.2.1 For pipes supplied as per this specification, the chemical composition of each heat of steel on product analysis shall be as given in Table 5 of this specification.

Table 5 of API Spec 5L stands replaced by Table 5 of this specification.

**Table 5 - Chemical composition for pipe**

Element	Mass fraction based upon heat and product analyses (%)	
C <sup>b</sup>	0.16	max.
Si	0.15 <sup>m(new)</sup>	min.
	0.40	max. (For Grade B to X46)
	0.45	max. (For Grade X52 to X70)
Mn <sup>b</sup>	1.20	max. (For Grade B to X42)
	1.40	max. (For Grade X46 & X70) for delivery conditionN
	1.50	max. (For Grade X46 & X56) for delivery conditionQ
	1.60	max. (For Grade X60 to X70) for delivery conditionQ
P	0.020	max.
S	0.010	max.
V	<sup>c</sup>	(For Grade B)
	0.05	max. (For Grade X42 to X52)
	0.07 <sup>g</sup>	max. (For Grade X56)
	0.08 <sup>g</sup>	max. (For Grade X60 to X70)
Nb	<sup>c</sup>	(For Grade B)
	0.05 <sup>g</sup>	max. (For Grade X42 to X70)
Ti	0.04 <sup>g</sup>	max. (For Grade B to X60)
	0.06 <sup>g</sup>	max. (For Grade X65 & X70)
Al <sup>a(new)</sup>	0.07	max.
Cr	0.20	
Mo	0.10	
Cu	0.35	
Ni	0.20	
N <sup>n(new)</sup>	0.012	



# PROCUREMENT OF API 5L 3LPE COATED CS LINE PIPE



TENDER DOCUMENT NO:  
GSL/REPL/012/STPL

Date: 19/01/2023

B	0.0005	
<p>a Based upon product analysis as per clause 9.2.4 and 9.2.5 of API Spec 5L, the CE<sub>Pcm</sub> limits apply if C ≤ 0.12% and CE<sub>nw</sub> limits apply if C &gt; 0.12%. For pipes of all grades, sizes and wall thicknesses, Carbon Equivalent shall comply with the following limits:</p> <p>CE<sub>Pcm</sub> ≤ 0.20 %  CE<sub>nw</sub> ≤ 0.40%</p> <p>Boron content shall be considered in CE<sub>Pcm</sub> formula even if it is less than 0.0005%.</p> <p>b Nb + V = &lt; 0.06%  c Nb + V + Ti = &lt; 0.15%  d Cu + Ni = &lt; 0.40%</p>		

5.2.1 For heat analysis and product analysis, all the elements listed in Table 5 of this specification shall be analysed and reported, even if those are not purposely added but are present as residuals only.

If alloying elements other than those specified in Table 5 of this specification are added to the steel, the limits of the additional components shall be agreed with the Purchaser.

### 5.3 TENSILE PROPERTIES

5.3.2 The finished pipe (after all heat treatment & sizing operations) shall conform to the requirements of Table 7 of API Spec 5L and as modified herein.

The actual yield strength shall be as close as possible to the specified minimum yield strength (SMYS) but in no case it shall exceed the limits specified here under:

API Spec 5L Grade	Permissible in excess of SMYS, MPa (psi)
Up to and including X46	131 (19,000)
X52 to X60	125 (18,000)
X65 to X70	120 (17,400)

The ratio of body yield strength and body tensile strength of each test pipe on which yield strength and ultimate tensile strength are determined, shall not exceed 0.90.

The minimum elongation of base metal shall be determined in accordance with the formula given in foot note (f) of Table 7 of API Spec 5L, however, minimum elongation shall be at least 20% for t ≤ 12.7 mm and 22% for t > 12.7 mm.

### 5.3 CVN IMPACT TEST FOR PSL 2 PIPE

5.3.1 General

5.4.1.2 From the set of three Charpy V-notch impact test pieces, only one is allowed to be below the specified average absorbed energy value and shall meet the minimum single absorbed energy value requirement as specified in Table 8 of this specification.

5.3.2 Pipe body tests

5.3.2.1 The average (set of three test pieces) absorbed energy value (KvT) for each pipe body test shall be as specified in Table 8 of this specification, based upon full sized test pieces at a test temperature of 0°C(32°F) and at -29° C (- 20°F).Table 8 of API Spec 5L stands replaced by Table 8 of this specification.

**Table 8 - CVN absorbed energy requirements for pipe body, weld and HAZ of PSL 2 pipe**

Pipe Grade	Full-size CVN absorbed energy (KvT) <sup>a,b</sup> [J]	
	Average	Minimum
B	40	33
X42	40	33
X46	40	33
X52	40	33
X56	40	33
X60	42	35
X65	45	38
X70	50	40

a. The minimum average (of a set of three test pieces) absorbed energy for each pipe weld and HAZ test, based on full-size test pieces and a test temperature of -29 ° C (-20°F) shall be 27 J & for individual test piece it shall be 22 J. (Applicable only for -29 °C, for other temperatures refer table above.)

5.3.2.2 The minimum average (set of three test pieces) shear fracture area shall be at least 85 % with one minimum value of 75%, based at a test temperature of 0°C (32 OF) and at -29° C (-20°F).

**5.4 SURFACE CONDITIONS, IMPERFECTIONS AND DEFECTS**

5.5.2 General

5.5.2.2 All pipes shall be free from cracks, sweats, leaks and slivers. Pipe containing such defects shall be treated in accordance with clause C.3 b) or C.3 c) of API Spec 5L.

5.5.3 Laminations

Any lamination or inclusion either extending into the face or bevel of the pipe or present within 50 mm from pipe ends shall be classified as defect. Pipes that

contain such defects shall be rejected or cut back until no lamination or inclusion is present at the pipe ends and shall be treated in accordance with clause C.3 b) or C.3



**PROCUREMENT OF API 5L 3LPE COATED CS LINE PIPE**



TENDER DOCUMENT NO:  
GSL/REPL/012/STPL

**Date: 19/01/2023**

c) of API Spec 5L.

5.5.4 Geometric deviations

5.5.4.2 For dents, the length in any direction shall be  $\leq 0.5 D$  and the depth, measured as the gap between the extreme point of the dent and the prolongation of the normal contour of the pipe, shall not exceed the following:

a) 2 mm for types of dents and not encroaching upon the minimum specified wall thickness

Dents that exceed the above specified limits shall be considered as defect and shall be treated in accordance with clause C.3 b) or C.3 c) of API Spec 5L. Acceptable cold-formed dents with sharp-bottom gouges shall be treated in accordance with clause C.2 of API Spec 5L & as modified in this specification.

5.5.5 Hard Spots

Any hard spot larger than 50 mm (2.0 in) in any direction and hardness greater than 248HV 10 shall be classified as defect and treated in accordance with clause C.3 of API Spec 5L.

5.5.6 Other surface imperfection

Other surface imperfections found by visual inspection or non-destructive inspection shall be investigated, classified and treated as follows:

5.5.6.2 Imperfections that have a depth  $\leq 0.05 t$  and do not encroach on the minimum specified wall thickness shall be classified as acceptable imperfections and shall be treated in accordance with Clause C.1 of this specification.

5.5.6.3 Imperfections that have a depth  $> 0.05 t$  and do not encroach on the minimum specified wall thickness shall be classified as defects, and shall be dressed-out by grinding in accordance with Clause C.2 of API Spec 5L and as modified in this specification or shall be treated in accordance with clause C.3 of API Spec 5L.

5.5.6.4 Imperfections that have a depth  $> 0.05 t$  and encroach on the minimum specified wall thickness shall be classified as defects and treated in accordance with clause C.3 of API Spec 5L.

5.6 DIMENSIONS, MASS AND TOLERANCES

5.6.2 Tolerances for diameter, wall thickness, length and straightness

5.6.3 The diameter and out-of-roundness shall be within the tolerances given in Table 10 of this specification.

Table 10 of API Spec 5L stands replaced by Table 10 of this specification.

**Table 10 - Tolerances for diameter and out-of-roundness**

	Diameter tolerances <sup>d</sup>	Out-of-roundness
--	----------------------------------	------------------



# PROCUREMENT OF API 5L 3LPE COATED CS LINE PIPE



TENDER DOCUMENT NO:  
GSL/REPL/012/STPL

Date: 19/01/2023

Specified outside Diameter (D)mm (inch)	Pipe except the end <sup>a</sup>	Pipe end <sup>a,c</sup>	Pipe except the end <sup>a</sup>	Pipe end <sup>a,c</sup>
114.3 (4 1/2) =< D = < 168.3 (6 3/8)	± 0.0075 D	-0.4 mm to + 1.6mm	0.020D	2.0mm
168.3 (6 3/8) <D = < 273.1 (10 3/4)		±0.005 D, but maximum of ± 1.6mm		2.0mm
273.1 (10 3/4) < D > 406.4 (16)				3.0mm

a The pipe end includes a length of 100 mm at each of the pipe extremities.  
b The diameter tolerance and out-of-roundness tolerance shall apply on insidediameter. The inside diameter, based on circumferential measurement, shall be calculated as ID = (D – 2t).  
c For determining compliance to the diameter tolerances, the pipe diameter isdefined as the circumference of the pipe in any circumferential plane divided by Pi (π).  
d Out-of-roundness tolerances apply to maximum and minimum diameters as (New) measured with bar gage, caliper, or device measuring actual,maximum and minimum diameters.

5.6.3.1 In addition to API requirements, the wall thickness of each pipe shall be checked along the circumference at both ends and at the mid location of pipe body at 12 O' clock, 3 O' clock, 6 O' clock and 9 O' clock positions. The tolerances for wall thickness shall be as given in Table 11 of this specification.

Table 11 of API Spec 5L stands replaced by Table 11 of this specification.

**Table 11- Tolerances for wall thickness**

Wall thickness (mm)	Tolerances c, d (mm)
t < 10.0	+0.225 t -0.05 t
10.0 = < t < 25.0	+0.20 t -0.05 t
t ≥ 25.0	+5.00 -1.25

a The + ve tolerance for wall thickness does not apply to the weld area.  
B See 9.13.2 of API Spec 5L and as modified herein for additional restrictions.

5.6.3.2 All pipes shall be supplied with length between 11.5 m and 12.5 m. However pipe with length between 10.0 m and 11.5 m can also be accepted for a maximum of 5% of the ordered quantity. Overall length tolerance shall be (-) Zero and (+) One pipelength to complete the ordered quantity. Table 12 of API Spec 5L stands deleted.

5.6.3.3 The tolerances for straightness shall be as follows:



## PROCUREMENT OF API 5L 3LPE COATED CS LINE PIPE



TENDER DOCUMENT NO:  
GSL/REPL/012/STPL

Date: 19/01/2023

5.6.3.3.1 The total deviation from a straight line over the entire pipe length shall not exceed 12 mm, as shown in Figure I of API Spec 5L.

5.6.3.3.2 The local deviation from straight line in 1.0 m (3.0 ft) portion at each pipe end shall be  $\leq 3.0$  mm (0.120 in), as shown in Figure 2 of API Spec 5L.

### 5.7 FINISH OF PIPE ENDS

#### 5.7.1 Plain ends

During removal of inside burrs at the pipe ends, care shall be taken not to remove excess metal and not to form an inside cavity on bevel. Removal of excess metal beyond the minimum wall thickness as indicated in clause 5.6.3.1 of this specification shall be a cause for re-bevelling. In case root face of bevel is less than that specified, the pipe ends shall be re-bevelled and rectification by filing or grinding shall not be done.

#### 5.7.4 Bevel Protectors

Both pipe ends of each pipe shall be provided with metallic or high impact plastic bevel protectors as per Manufacturer's standard. Bevel protectors shall be of a design such that they can be re-used by coating applicator for providing on externally anti-corrosion coated pipes subsequent to coating of line pipe.

## 6. INSPECTION

### 6.2 TYPES OF INSPECTION AND INSPECTION DOCUMENTS

#### 6.2.1 Inspection documents for PSL 2 pipes

6.2.1.1 Inspection certificate 3.2 in accordance with EN 10204 shall be issued for each dispatched pipe by Purchaser's authorized representative.

### 6.3 SPECIFIC INSPECTION

#### 6.3.1 Inspection frequency

6.3.1.2 For PSL 2 pipe, the inspection frequency shall be as given in Table 18 of this specification.

Table 18 of API Spec 5L stands replaced by Table 18 of this specification.

**Table 18 - Inspection frequency of pipe**

SI. no.	Type of inspection	Frequency of inspection
1	Heat analysis <sup>a</sup>	One analysis per heat of steel
2	Product analysis <sup>b</sup>	Two pipes per lot (maximum 100 pipes) per heat
3	Tensile testing of the pipe body	Two pipes per lot (maximum 100 pipes) per heat
4	CVN impact testing of the pipe body	Once per test unit of not more than 100 pipes
5	Vickers hardness testing of Pipe body	Once per test unit of not more than 50 pipes
6	Hydrostatic testing	Each pipe
7	Visual inspection	Each pipe
8	Pipe diameter and out-of roundness <sup>d</sup>	Each pipe
9	Wall thickness measurement <sup>d</sup>	Each pipe
10	Straightness <sup>d</sup>	At least 3 times per operating shift (12 hours maximum)
11	Other dimensional testing	Random testing, with the details left to the discretion of the manufacturer
12	Weighing of pipe	Each pipe shall be measured and recorded
13	Non-destructive inspection	In accordance with Annex E of APISpec 5L and as modified herein
14	Length	Each length of pipe shall be measured and recorded

a Where the steel mill is not a part of an integrated pipe mill, heat analysis shall be reported by the Manufacturer prior to start of pipe production.

b Pipes selected shall be such that one at the beginning of the heat and one at the end of the heat are also represented.

c Deleted.

d Measurement shall be recorded at least 3 times per operating shift (12 hrs maximum).

e "Test unit" is as defined in clause 4.62 of API Spec 5L.

#### 6.2.1 Samples and test pieces for product analysis

Samples shall be taken, and test pieces prepared, in accordance with ISO 14284 or ASTM

E1806. Samples used for product analysis shall be taken from finished pipes only.

6.2.2 Samples and test pieces for mechanical tests

6.2.2.1 General

In addition to API Spec 5L requirements, samples and test pieces for various types of tests shall be taken from Figure 5 a) of API Spec 5L and Figure 10.2.4.8.1 of this specification, whichever is applicable, and as given in Table 20 of this specification.

Table 20 of API Spec 5L stands replaced by Table 20 of this specification.

**Table 20 - Number, orientation and location of test pieces per sample for mechanical tests**

Sample Location	Type of test	Number, Orientation and location of test pieces per sample a
Pipe body	Tensile	1L, 1T <sup>b</sup>
	CVN	3T
	Hardness	1T
A See figure 5 (b) of API Spec 5L for an explanation of the symbols used to designate orientation and location.		
B The transverse tensile tests shall be carried out on pipes of D >= 219.1 mm.		

6.3.1.1 Test pieces for the tensile test

Tensile test specimens shall be taken from finished pipes only. Heating or artificial ageing of test pieces is not permitted.

Transverse test pieces shall have a round cross-section and shall be obtained from non-flattened samples prepared according to ASTM A370.

Longitudinal tensile tests shall be carried out on a strip specimen representing full wall thickness of the pipe prepared according to ASTM A370.

6.3.1.2 Test pieces for the CVN impact test

In addition to the API Spec 5L requirements, following shall also be applicable:

The test pieces shall be prepared in accordance with ASTM A370. Non-flattened test pieces shall be used. Test specimen shall be taken from the body of the finished pipe only.



## PROCUREMENT OF API 5L 3LPE COATED CS LINE PIPE



TENDER DOCUMENT NO:  
GSL/REPL/012/STPL

**Date: 19/01/2023**

The axis of the notch shall be perpendicular to the pipe surface.

Charpy V-notch impact testing shall be performed on full-sized test pieces. However, if preparation of full size test piece is not possible, then standard sub-sized test pieces shall be prepared as per ASTM A370.

In case of lower pipe sizes wherein preparation of transverse sub-sized specimen is not possible, CVN impact testing shall be carried out on longitudinal test specimen [see Note 'a' of Table 8 of this specification].

### 6.3.1.3 Samples for hardness tests

(New) Samples for hardness tests shall be taken transverse to the pipe body [see Figure 5 a) key 2] from the pipe ends.

### 6.3.2 Test methods

6.3.4.1 CVN impact test The Charpy test shall be carried out in accordance with ASTM A370.

### 6.3.4.2 Hardness test

In addition to the requirements of API Spec 5L, following shall also be applicable:

Vickers hardness tests shall be carried out in accordance with ISO 6507-1. The resulting Vickers hardness value at any point shall not exceed 248 HV<sub>10</sub>. Hardness test locations shall be as shown in Figure 10.2.4.8.1 of this specification.

Modalities of retest shall be in accordance with clause 10.2.12.7 of API Spec 5L.

### 6.3.4.3 Hydrostatic test

6.3.4.3.1 Test pressure shall be held for a minimum period of 15 seconds for all sizes and grades of pipes.

6.3.4.4 In addition to the requirements of API Spec 5L, following shall also be applicable:

The pressure gauge used for hydrostatic testing shall have a minimum range of 1.5 times and maximum range of 4 times the test pressure. The test- pressure measuring device shall be calibrated by means of a dead-weight tester only. The test configuration shall permit bleeding of trapped air prior to pressurization of the pipe.

6.3.4.5 The test pressure for all sizes and grades of pipe shall be such that hoop stress (fibrestress) generated is at least 95% of SMYS, computed based on the Equation (6) indicated in clause 10.2.6.5 of API Spec 5L. Table 26 of API Spec 5L stands deleted.

### 6.3.3 Visual inspection

6.3.5.2 Each pipe shall be visually examined for entire external surface and internal surface to the



## PROCUREMENT OF API 5L 3LPE COATED CS LINE PIPE



TENDER DOCUMENT NO:  
GSL/REPL/012/STPL

Date: 19/01/2023

extent feasible and shall be free of defects in finished condition. Visual examination shall be carried out in a sufficiently illuminated area; minimum 1000 lx. If required additional lights shall be used to obtain good contrast and relief effect between imperfections and backgrounds.

### 6.3.4 Dimensional testing

6.3.6.2 Diameter measurements shall be made with a circumferential tape only.

6.3.6.3 The measuring equipment requiring calibration or verification under the provisions of API Spec 5L shall be calibrated with manual instruments at least once per operating shift (12 hours maximum). Such calibration records shall be furnished to Purchaser's Representative on request.

### 6.3.5 Non-destructive inspection

Non-destructive inspection shall be performed in accordance with Annex E of API Spec 5L and as modified herein.

### 6.3.6 Reprocessing

This clause of API Spec 5L stands cancelled.

### 6.3.7 Retesting

### 6.3.9.2 Recheck analyses

Modalities of recheck analysis shall be as per API Spec 5L as applicable to the lot being tested (see Table 18 of this specification). However, during individual testing, each pipe shall be fully analysed to meet the requirements of Table 5 of this specification.

## 7. MARKING

### 7.2 GENERAL

7.2.1 Pipe manufactured in accordance with this specification shall be marked by the manufacturer as per the requirements of API Spec 5L and as modified herein. Marking shall be in English language and International System (SI) of Units.

7.2.2 (New) The marking of finished line pipe should also contain the Purchase Order No, Item No, Pipe No, Heat No, coated pipe No, Inspection mark by TPI, Diameter of pipe and wall thickness (to be marked in white color).

### 7.3 Pipe markings

7.3.1 (New) Actual length in meters and actual pipe weight in kg shall be marked

7.3.2 (New) Paint used for stencil marking shall withstand a temperature up to 250°C expected



## PROCUREMENT OF API 5L 3LPE COATED CS LINE PIPE



TENDER DOCUMENT NO:  
GSL/REPL/012/STPL

Date: 19/01/2023

to be experienced during further external anti-corrosion coating operations of line pipe by coating applicator.

7.3.3 The pipe number shall be placed by cold rolling or low stress dot marking or vibrio-etching on the outside surface of the pipe at an approximate distance of 50 mm from both ends. In case of non-availability of either cold rolling or low stress dot marking facility in pipe mill, an alternative marking scheme of a permanent nature may be proposed by the Manufacturer

7.3.4 A Colour code band shall be marked on inside surface of finished pipe for identification of pipes of same diameter but different wall thickness, as indicated in the Purchase Order.

The Colour code band shall be 50 mm wide and shall be marked at a distance of 150mm from the pipe ends.

7.3.5 (New) Barcode identification system shall be provided by the pipe supplies, which shall have a life of 5 years over and above the conventional marking as per API 5L. The Manufacturer shall propose marking system to clearly identify the type of pipes.

### 8. COATINGS AND THREAD PROTECTORS

8.2 Unless otherwise specified in the Purchase Order, the pipes shall be delivered bare, free of any trace of oil, stain, grease and paint. Varnish coating shall be applied on the marking area. Bevels shall be free of any coating.

### 9. RETENTION OF RECORDS



In addition to the records indicated in API Spec 5L, the Manufacturer shall retain the records of all additional tests and calibration records mentioned in this specification including the hard copy records of ultrasonic testing carried out on pipe/coil as well as pipe ends.

### 10. PRODUCTION REPORT

(New) The Manufacturer shall provide one electronic copy and six hard copies of production report in English language indicating at least the following for each pipe. International system of units (SI) shall be adopted.

- Pipe number
- Heat number from which pipe is produced
- Pipe length and weight
- Pipe grade

The Manufacturer shall provide one electronic copy and six hard copies of acceptance

	<b>PROCUREMENT OF API 5L 3LPE COATED CS LINE PIPE</b>	
TENDER DOCUMENT NO: GSL/REPL/012/STPL		<b>Date: 19/01/2023</b>

certificates which shall include the results of all tests required as per this specification and performed on delivered material giving details of, but not limited to, the following:

- All test certificates as per clause 10.1.3 of API Spec 5L and as modified herein.
- Certified reports of dimensional inspection, surface imperfections & defects.
- Data on test failures, rejected heats/lots, etc.
- Information on production and shipping
- All other reports and results required as per this specification.

The certificates shall be valid only when signed by the Purchaser's Representative. Only those pipes, which have been certified by the Purchaser's Representative, shall be dispatched from the pipe mill.

In the event of small quantities of pipes supplied against this specification, the production report may consist of only test certificates required as per clause 10.1.3 of API Spec 5L and as modified herein and other test reports/results required as per this specification.

## **11. INSPECTION OF FIELD TESTS & WARRANTY**

(New) Purchaser shall be reimbursed by Manufacturer for any pipe furnished on this order that fails under field hydrostatic test if such failure is caused by a material/manufacturing defect in the pipe. The reimbursement cost shall include pipe, labour and equipment rental for finding, excavating, cutting out and installation of replaced pipe in position. The field hydrostatic test pressure will not exceed that value which will cause a calculated hoop stress equivalent to 95 percent of specified minimum yield strength.

**In case Manufacturer so desires, he will be advised at least two weeks in advance so that his Representative may witness the hydrostatic test in field, however, the testing and leak (if any) finding and repair operation shall not be postponed because of absence of the Manufacturer's Representative. Annex B**

### **Manufacturing Procedure Qualification for PSL 2 Pipe**

#### **B.1 INTRODUCTION**

B.1.1 This annex specifies additional provisions that apply for the PSL 2 pipes ordered as per this specification.

B.1.2 Two lengths each of completely finished pipes from two different heats (i.e. a total of four pipe lengths) shall be selected at random for testing as per clause B.5.1 of this specification to verify that the manufacturing procedure results in the quality of pipes which are in complete compliance with this specification. The pipes thus tested shall be considered to be the test pipes required per heat or per lot as per relevant



## PROCUREMENT OF API 5L 3LPE COATED CS LINE PIPE



TENDER DOCUMENT NO:  
GSL/REPL/012/STPL

Date: 19/01/2023

clauses of this specification.

These manufacturing procedure qualification tests (MPQT) shall be repeated upon any change in the manufacturing procedure as deemed necessary by Purchaser's Representative. The manufacturing procedure qualification tests shall be carried out on pipes for each wall thickness, each diameter and each grade of steel.

- B.1.3 Verification of the manufacturing procedure shall be by qualification in accordance with clause B.3, B.4 and B.5 of API Spec 5L and as modified herein.

Note: In the event of small quantities of pipes ordered against this specification, like those for bends and other similar applications, as specifically called out in the Purchase Order, the manufacturing procedure qualification test as per clause B.5.1 of this specification shall not be carried out. Pipes in such case shall be accepted based on regular production tests.

### **B.2 CHARACTERISTICS OF THE MANUFACTURING PROCEDURE SPECIFICATION**

Before pipe production commences, Manufacturing Procedure Specification (MPS) for manufacturing of pipes and Statistical process control charts shall be prepared by pipe manufacturer and submitted for approval of the Purchaser.

### **B.5 MANUFACTURING PROCEDURE QUALIFICATION TESTS (MPQT)**

- B.5.1 For the qualification of the manufacturing procedure, all tests & inspections specified in Table 18 and clause B.5.2 of this specification shall be conducted on all the pipes selected for testing as per clause B.1.2 of this specification.

- B.5.2 The Manufacturer shall submit to Purchaser a report giving the results of all tests mentioned below. The report shall be agreed and signed by Purchaser's Representative, prior to start of regular production.

The various tests to be conducted on each pipe shall be as follows. The test method and acceptance values shall be as per this specification unless specified differently in this Annex.

**a. Visual Examination**

All pipes shall be examined visually for dimensional tolerances and apparent surface defects.

**b. Ultrasonic Examination**

The weld seam of all pipes shall be examined ultrasonically by automatic ultrasonic equipment.

**c. Mechanical Properties**



## PROCUREMENT OF API 5L 3LPE COATED CS LINE PIPE



TENDER DOCUMENT NO:  
GSL/REPL/012/STPL

Date: 19/01/2023

The mechanical properties of all pipes shall be tested and shall meet the requirements of this specification. Purchaser's Representative will select the places in pipe from where the test pieces shall be extracted.

The following tests shall be conducted:

i. Tensile test

Tensile tests as per Table 20 and clause 6.3.3.2 of this specification shall be conducted on:

- Two (2) transverse test pieces for pipe of  $D < 219.1$  mm (8.625 inch):
- Two (2) longitudinal test pieces

ii. CVN impact testing

Four sets of three transverse specimens shall be extracted from base metal for CVN impact tests including fracture toughness testing. The specimen shall be tested at  $-40^{\circ}\text{C}$ ,  $-30^{\circ}\text{C}$ ,  $-20^{\circ}\text{C}$ ,  $-10^{\circ}\text{C}$ ,  $0^{\circ}\text{C}$ ,  $+10^{\circ}\text{C}$ ,  $+20^{\circ}\text{C}$  for shear area and absorbed energy to produce full transition curve. The value for shear area and absorbed energy at the test temperature specified in clause 5.4 and Table 8 of this specification respectively shall be complied with. For other temperatures, test values shall be for information only.

iii. Hardness test

Hardness test shall be conducted on selected pipes as per requirement of clause 6.3.4.3 of this specification.

In addition to the above tests, all the tests and inspections required to be conducted as per this specification shall be conducted on all the pipes selected for testing during MPQT.

### Treatment of surface imperfections and defects

**C.1 TREATMENT OF SURFACE IMPERFECTIONS**

Surface imperfection not classified as defect as per this specification shall be cosmetically dressed-out by grinding.

**C.2 TREATMENT OF DRESSABLE SURFACE DEFECTS**

- C.2.3 Complete removal of defects shall be verified by local visual inspection and by suitable non-destructive inspection. To be acceptable, the wall thickness in the ground area shall be in accordance with clause 5.6.3.1 of this specification.



**PROCUREMENT OF API 5L 3LPE COATED CS LINE PIPE**



TENDER DOCUMENT NO:  
GSL/REPL/012/STPL

**Date: 19/01/2023**

**STANDARD SPECIFICATION  
FOR  
3 LAYER POLYTHYLENE COATING OF LINEPIPES**



## PROCUREMENT OF API 5L 3LPE COATED CS LINE PIPE



TENDER DOCUMENT NO:  
GSL/REPL/012/STPL

**Date: 19/01/2023**

### CONTENTS

- 1.0 SCOPE
- 2.0 REFERENCE DOCUMENTS
- 3.0 MATERIAL REQUIREMENTS
- 4.0 COATING APPLICATION
- 5.0 INSPECTION AND TESTING
- 6.0 HANDLING, TRANSPORTATION AND STORAGE
- 7.0 REPAIR OF COATING AND FINAL ACCEPTANCE
- 8.0 MARKING AND PIPE IDENTIFICATION
- 9.0 PRODUCTION REPORT
- 10.0 QUALITY ASSURANCE



## PROCUREMENT OF API 5L 3LPE COATED CS LINE PIPE



TENDER DOCUMENT NO:  
GSL/REPL/012/STPL

Date: 19/01/2023

### SCOPE

This Specification covers the minimum requirements for supply/arrangement of all materials, plant, equipment, plant sites, consumables, utilities and application including all labor, supervision, inspection and tests etc. for application of external anti-corrosion coating of pipes by using Three Layer Side Extruded Polyethylene coating conforming to DIN-30670, 2012, 'Polyethylene Coating for Steel Pipes and Fittings' and the requirements of this specification.

### 2.0 REFERENCE DOCUMENTS

#### 2.1. CODES AND STANDARD

Reference has also been made to the latest edition (edition enforce at the time of issue of enquiry unless otherwise specify) of the following Standards, Codes and Specifications. The edition enforce at the time of floating the enquiry shall be termed as latest edition.

#### AMERICAN SOCIETY FOR TESTING AND MATERIALS (ASTM)

- ASTM D-149 Standard Test Methods of Dielectric Breakdown Voltage and Dielectric Strength of Solid Electrical Insulating Material at commercial frequencies.
- ASTM D-257 Standard Test Methods for D-C Resistance or Conductance of Insulating Materials
- ASTM D-543 Standard Method of Test for Resistance of Plastics to Chemical Reagents
- ASTM D-570 Standard Method of Test for Water Absorption of Plastics ASTM D-638 Standard Method of Test for Tensile Properties of Plastics
- ASTM D-792 Standard Test Method for Density and Specific Gravity (Relative Density) of Plastics by Displacement
- ASTM D-1238 Test Method for Flow Rates of Thermoplastics by Extrusion ASTM D-1525 Test Method for Vicat Softening Temperature of Plastics ASTM D-1603 Test Method for Carbon Black in Olefin Plastics
- ASTM D-1693 Test Method for Environmental Stress Cracking of Ethylene Plastics
- ASTM D-2240 Test Method for Rubber Property - Durometer Hardness STM D-3895 Test Method for Oxidative-Induction Time of Polyolefin by Differential Scanning Calorimetry
- ASTM G-42 Tentative Methods for Cathodic Disbonding of Pipeline coatings Subjected to Elevated or Cyclic Temperatures

#### AMERICAN PETROLEUM INSTITUTE (API)



## PROCUREMENT OF API 5L 3LPE COATED CS LINE PIPE



TENDER DOCUMENT NO:  
GSL/REPL/012/STPL

Date: 19/01/2023

API 5L	Specification for Line Pipe
API RP 5L 1 5LW	Recommended Practice for Railroad Transportation of Line pipe API RP Transportation of Line Pipe on Barges and Marine Vessels

### DEUTSCHES INSTITUT FUR NORMUNG (DIN)

EN 10204	Metallic Products - Types of Inspection Documents
DIN 53735 30670	Testing of Plastics: Determination of Melt Index of Thermoplastics DIN Polyethylene Coating for Steel Pipes and Fittings.

### INTERNATIONAL STANDARD (IS)

ISO 8502 - 3	Preparation of Steel Substrates before Application of Paints and Related Products part 3 - Assessment of Dust on Steel Surfaces Prepared for Painting (Pressure Sensitive Tape Method)
ISO 11124	Preparation of Steel Substrates Before Application of Paints and Related Products

### AMERICAN SOCIETY OF MECHANICAL ENGINEERS (ASME)

ASME B31.8	Gas Transmission and Distribution Piping Systems. Liquid
ASME B31.4	Transportation Systems for Hydrocarbons, Liquid, Petroleum Gas, Anhydrous Ammonia, and Alcohols

### CANADIAN STANDARD ASSOCIATION (CSA)

CSA Z245.20-18	External Fusion Bond Epoxy Coating for Steel Pipe
----------------	---

## 3.0 MATERIAL REQUIREMENTS

### 3.1. FUNCTIONAL REQUIREMENT

The three layer coating system shall comprise of a powder epoxy primer, polymeric adhesive and a polyethylene topcoat. Coating materials shall be suitable for the service conditions and the pipe sizes involved. The coating materials i.e. epoxy powder; adhesive and polyethylene compound shall have proven compatibility. The coating system and materials shall be pre-qualified and approved by Company in accordance with provisions of Annexure I of this specification. Contractor shall obtain prior approval from Company for the coating system and coating materials.

#### 3.1.1 OPERATING TEMPERATURE

The coating must be able to withstand minimum and maximum continuous in-service



## PROCUREMENT OF API 5L 3LPE COATED CS LINE PIPE



TENDER DOCUMENT NO:  
GSL/REPL/012/STPL

Date: 19/01/2023

operating temperatures of 0°C and (+) 65°C respectively and still comply with the performance requirements of this specification.

### EXPOSURE TO ENVIRONMENT

The coating materials shall withstand exposure to ultraviolet radiation (i.e. sunlight) and heat due to exposure to sunlight with a daytime coating temperature of at least 80°C without impairing its serviceability and properties specified

### 3.2. PROPERTIES

#### 3.2.1 GENERAL

The 3 Layer Polyethylene coating shall conform to DIN 30670, Type „S“ and the requirements of this specification.

#### 3.2.2 FUSION BONDED EPOXY (FBE) POWDER

Epoxy powder shall comply Canadian Standard Association (CSA) Standard Z245.20-2018. The color of epoxy powder shall be either green or dark red or any other color approved by Company except grey.

#### 3.2.3 ADHESIVE

Co-polymer adhesive used shall be grafted type and the adhesive shall have the following properties:

Sr. No.	Properties	Unit	Requirement	Test Method
a	Melt Flow Rate (190°C / 2.16 kg)	g/10 minutes	1.0 min.	ASTM D 1238
b	Vicat Softening Point	°C	100 min.	ASTM D 1525
c	Specific Gravity	-	0.926 min	ASTM D 792

#### 3.2.4 POLYETHYLENE COMPOUND

Sr. No.	Properties	Unit	Requirement	Test Method
---------	------------	------	-------------	-------------

a	Tensile Strength @ + 25 °C	N/mm <sup>2</sup>	17 min.	ASTM D 638
b	Melt Flow Rate (190 °C / 2.16kg)	g/10 minutes	0.25 min.	ASTM D 1238 or DIN 53735
c	Specific Gravity @ + 25 °C	--	0.926 min.(MDPE) 0.941 min. (HDPE)	ASTM D 792
d	Hardness @ + 25 °C	Shore D	50 min	ASTM D 2240
e	Water Absorption, 24 hours, @+ 25 °C	%	0.05 max	ASTM D 570
f.	Volume Resistivity @ + 25°C	Ohm-cm	10 <sup>15</sup> min.	ASTM D 257
g	Dielectric withstand, 1000 Volt/sec rise @ + 25 ° C	Volts/mm	30,000 min.	ASTM D 149
h	Vicat Softening Point	°C	110 min.	ASTM D 1525
i	Elongation	%	600 min	ASTM D 638
j	Oxidative Induction Time in Oxygen at 220°C, Aluminum pan, no screen	Minutes	10	ASTM D3895
k.	Environmental Stress Crack Resistance (ESCR) (for F <sub>50</sub> ) ■ Medium Density [Condition "C"] ■ High Density [Condition "B"]	Hours	300 300	ASTM D1693
l	Carbon Black Content	%	2 min.	ASTM D 1603

### 3.2.5 COATING SYSTEM PROPERTIES

Sr. No.	Properties	Unit	Requirement	Test Method
a	Bond Strength (using Type 2 Test Assembly i.e. Dynamometer <ul style="list-style-type: none"> <li>• @ 20+/-5 ° C</li> <li>• @ 65+/-5°C</li> </ul>	Kg/cm	8.0 min 5.0 min	DIN 30670



b	Impact Strength (Min. of 30 impacts on body along the length. No breakdown allowed when tested at 25 KV)	Joules per mm of coating thickness	7 min	DIN 30670
c	Indentation Hardness <ul style="list-style-type: none"> <li>• @ 23 +/- 2°C</li> <li>• @ 70 +/- 2°C</li> </ul>	mm	0.2 max 0.3 max	DIN 30670
d	Elongation at Failure	%	300 min.	DIN 30670
e	Coating Resistivity (*)	Ohm - m <sup>2</sup>	10 <sup>8</sup> min.	DIN 30670
f.	Heat Ageing (*)	-	Melt Flow Rate shall not deviate by more than 35% of original value	DIN 30670
g	Light Ageing (*)	-	Melt Flow Rate shall not deviate by more than 35% of original value	DIN 30670
h	Cathodic Disbondment <ul style="list-style-type: none"> <li>• @ +65 °C after 30 days</li> <li>• @ +65 °C after 48 hrs</li> </ul>	mm radius of disbondment  (**)	15 max. 7 max.	ASTM G42
i	Degree of Cure of Epoxy <ul style="list-style-type: none"> <li>• Percentage Cure, ΔH</li> <li>• ΔTg</li> </ul>	%  °C	95 ≤ 5	CSA Z 245.20-18 (***)

**NOTES**

- (\*) Test carried out in an independent laboratory of national/international recognition on PE topcoat is also acceptable.
- (\*\*) Disbondment shall be equivalent circle radius of total unsealed area as per ASTM G42.
- (\*\*\*) Temperature to which the test specimens are to be heated during cyclic heating shall however be as per the recommendations of epoxy powder manufacturer

**3.2.6** The acceptable combinations of coating material shall be as per Annexure-I

**3.3. REPAIR MATERIAL**

	<b>PROCUREMENT OF API 5L 3LPE COATED CS LINE PIPE</b>	
TENDER DOCUMENT NO: GSL/REPL/012/STPL		<b>Date: 19/01/2023</b>

Repair material shall be such that is capable of complying with the functional requirements stated for 3LPE coating under Para 3.1 above and shall be compatible with the 3LPE coating.

#### **3.4. MATERIAL APPROVAL**

The coating materials shall be pre-qualified and approved by the Company. Contractor shall submit data sheets of proposed material combinations to Company for prior approval. The data sheets shall cover all aspects required by this specification. The materials brands offered by Contractor for coating (i.e. Epoxy powder, co-polymer adhesive and the polyethylene compound) shall have proven compatibility. The contractor shall submit compatibility certificates from manufacturers in this regard. Only Company approved materials/combination of materials shall be used for coating of pipes

#### **3.5. MATERIAL CERTIFICATES**

For each batch of all materials, the Contractor shall obtain from the manufacturer(s) relevant certificates of material conformity and test results as per DIN 10204, 3.1 b. These certificates shall be submitted to Company for approval prior to the use of material for coating application. In addition to Manufacturer's certificate, the Contractor shall draw samples from each batch of epoxy, adhesive and polyethylene in the presence of Company Representative and test for the following properties at the coating yard at least one week prior to its use, to establish compliance with the Manufacturer's test certificates.

#### **3.6. MATERIAL IDENTIFICATION**

All materials to be used shall be packed in damage free containers suitably marked with the following minimum information for identification:

- a. Name of the manufacturer.
- b. Type of material and product designation.
- c. Batch Number.
- d. Date and place of Manufacture
- e. Shelf Life / Expiry Date
- f. Storage Conditions
- g. Quantity

Any materials found without above identification markings shall be deemed suspect and rejected by Company. Rejected materials shall be promptly removed and replaced by the Contractor. Coating materials shall be segregated by batch number during shipment, storage and handling.



## PROCUREMENT OF API 5L 3LPE COATED CS LINE PIPE



TENDER DOCUMENT NO:  
GSL/REPL/012/STPL

Date: 19/01/2023

### 3.7. INFORMATION FOR FBE MATERIAL

Contractor shall obtain Infrared scan of each batch of epoxy powder to assure that powder used in manufacturing is same as powder used in qualification.

### 3.8. MATERIALS STORAGE

Coating materials shall be stored, handled and transported in accordance with the Manufacturer's recommendations. Storage time of materials shall not exceed the shelf life recommended by the Coating Manufacturer. The contractor shall be required to use all material on a date received rotation basis i.e. first in first used basis.

### 3.9. MATERIAL SUBSTITUTION

Contractor shall not substitute Company approved materials with alternative materials, even if alternative materials comply with the requirements of this specification, without written approval from Company.

### 3.10. ABRASIVE MATERIALS

Abrasives used for blast cleaning shall be clean, free of oil or contaminants and dry. The particle size shall be capable of producing the specified surface profile and roughness. Abrasive materials shall meet the requirements of ISO 11124-1.

## 4.0 COATING APPLICATION

### 4.1. COATING APPLICATION PROCEDURE SPECIFICATION

Prior to the commencement of any coating application activities, the Contractor shall submit a project specific Coating Application Procedure Specification, giving full details of the proposed coating process for Company's approval. The Coating Application Procedure Specification shall include, but not be limited to, the following information and proposals:

- a. Inspection of bare pipes and removal of surface defects and surface contaminants.
- b. Steel surface preparation, including preheating, removal of steel defects, method of pipe cleaning, dust removal, abrasive blast cleaning and surface profile; methods of measurements and consumables.
- c. Pipe heating, temperatures and control prior to epoxy application.
- d. Complete details of raw materials including current data sheets showing values for all the properties specified together with quality control and application procedure recommendations from manufacturer(s).



## PROCUREMENT OF API 5L 3LPE COATED CS LINE PIPE



TENDER DOCUMENT NO:  
GSL/REPL/012/STPL

Date: 19/01/2023



- e. Application of FBE powder, adhesive and polyethylene, including characteristics, temperature, line speed, application window, curing time, etc.
- f. Quenching and cooling, including time and temperature.
- g. Quality Assurance System, Quality Plan, Inspection and Test Plan and reporting formats, including instrument and equipment types, makes and uses, etc
- h. Detailed method of repair of coating defects duly classified depending upon nature and magnitude of defects and repair thereof including coating stripping technique.
- i. Details of instrument and equipment calibration methods and frequency of calibration including relevant standards and examples of calibration certificates.
- j. Complete details and inventory of laboratory and equipment for procedure qualification and regular production.
- k. Pipe handling and stock piling procedures.
- l. Sample of recording and reporting formats, including laboratory reports, certificates and requirement.
- m. Complete details of test certificates for raw materials including test methods and standards used.
- n. Test certificates from PE compound manufacturer for tests for thermal aging, coating resistivity and aging under exposure to light. These test certificates shall not be older than three years.
- o. Storage details of coating materials and chemicals.
- p. Continuous temperature monitoring at various stages of coating
- q. Health, Safety and Environmental (HSE) plans for the storage of raw materials and coating application.
- r. Procedure for transferring of bare pipe identification numbers and applying coated pipe identification marking.

Coating application shall proceed only after written approval from Company has been obtained on the Coating Application Procedure Specification.

Contractor shall submit the detailed Inspection and Testing Plan (ITP) mentioned for the entire coating application to Company for review and approval. The Company will advise the Contractor of the specific inspection review, witness and HOLD points required by the Company or its Representatives by marking up the ITP.

After approval of the Coating Application Procedure Specification and ITP by the Company no changes shall be in the procedure specification or ITP shall be permitted. Unavoidable changes, if any, shall be brought to the notice of Company and specific written approval obtained before implementing the same.

### 4.2. COATING APPLICATION PROCEDURE QUALIFICATION

	<b>PROCUREMENT OF API 5L 3LPE COATED CS LINE PIPE</b>	
TENDER DOCUMENT NO: GSL/REPL/012/STPL		<b>Date: 19/01/2023</b>

#### **4.2.1. GENERAL**

Prior to start of production, the Contractor shall, at his expense, carry out a coating PQT for each pipe diameter on max. wall thickness, for each type of pipe, for each coating material combination, and for each plant, to prove that his plant, materials, and coating procedures result in a quality of end product conforming to the properties stated in clause 3.2, relevant standards, specifications and material manufacturer's recommendations.

Contractor shall give seven (7) working days' notice to witness all procedures and tests.

A batch representing a normal production run, typically 15 pipes, shall be coated in accordance with the approved coating procedure and the coating operations witnessed by Company Representative. Out of these pipes, at least one pipe shall be coated partly with epoxy and partly with both epoxy and adhesive layers.

At least 5 (five) test pipes shall be selected by Company Representative for coating procedure approval tests and shall be subjected to procedure qualification testing as described hereinafter. Company Representative shall witness all tests. Out of 5 (five) test pipes, 1 (one) pipe partly coated with epoxy and partly coated with both epoxy and adhesive layers shall be included. Remaining 4 (four) test pipes shall have all three layers. During PQT, the Contractor shall qualify various procedures forming a part of coating operations as detailed subsequently.

#### **4.2.2. PIPE PRE-HEATING**

Temperature variation due to in-coming pipe temperature, line speed variation, pipe wall thickness variation, emissivity, interruptions, etc. shall be established and documented during PQT stage. Proper functioning of pipe temperature monitoring and recording system including audible alarm shall be demonstrated.

#### **4.2.3. SURFACE PREPARATION**

The procedure to clean and prepare the pipe surface shall be in accordance with the requirements of this specification. The ratio of shot to grit shall be established during procedure qualification testing, such that the resultant surface profile is not dished and rounded. The qualification shall be performed through a visual inspection, measurement of roughness and check of the presence of dust on the abrasive blast cleaned pipe surface.

#### **4.2.4. CHEMICAL PRE-TREATMENT**

##### **4.2.4.1 PHOSPHORIC ACID WASH FOLLOWED BY DE-IONIZED WATER WASH**

The procedure to apply the chemical pre-treatment viz. phosphoric acid wash followed by de-ionized water wash shall result in intended cleaning requirements of this specification. Working solution preparation, maintaining concentration, application procedure including



## PROCUREMENT OF API 5L 3LPE COATED CS LINE PIPE



TENDER DOCUMENT NO:  
GSL/REPL/012/STPL

Date: 19/01/2023

method of spreading, spreading rate, drying times, etc. depending upon the cleanliness/temperature of the incoming pipe and the line speed shall be established. Temperature of the chemical, pipe pre-heat temperature vs line speed vs dwell time, rinsing procedure, testing & control, rectificatory measures, drying procedure etc. shall be clearly established during PQT. Also the quality of the de-ionized water shall be established during PQT.

### 4.2.4.1 CHROMATE TREATMENT

The procedure to apply the chromate treatment shall result in intended cleaning requirements of this specification. Working solution preparation, maintaining concentration, application procedure including method of spreading, spreading rate, drying times, etc. depending upon the temperature of the incoming pipe and the line speed shall be established. Temperature of the chemical, pipe pre-heat temperature vs. line speed, pipe heating after chromating and time limit within which the pipe to be heated, testing & control, rectificatory measures, shall be clearly established during PQT

### 4.2.5. PIPE HEATING AND EPOXY POWDER APPLICATION

Parameters affecting pipe heating such as rating and frequency of induction heater or number of burners in case of gas heating vis-à-vis pipe thickness and line speed and epoxy application such as air pressure in the spray guns, dew point of air, pipe surface temperature, etc. shall be established and documented so that specified minimum epoxy thickness and other coating quality requirements are met with.

In addition quality and quantity of epoxy that can be recycled shall be established. For this purpose, samples of reclaimed epoxy powder shall be drawn and subjected to visual examination, thermal analysis and moisture content testing. Only if the properties of reclaimed epoxy are established to be within manufacturer specified range, reclaimed epoxy shall be allowed to be recycled. Contractor shall also establish maximum quantity of reclaimed epoxy that can be mixed with fresh epoxy without affecting quality of coating.

### 4.2.6. ADHESIVE AND PE APPLICATION

Parameters affecting application of co-polymer adhesive and polyethylene layers such as line speed, fusion bonded epoxy curing time and temperature of co-polymer adhesive and polyethylene, quenching time and temperature, etc. shall be established and documented so that specified minimum coating thickness and other quality requirements specified are met with.

### 4.2.7. TESTING

At least five (5) test pipes, including one (1) pipe partly coated with epoxy and one (1) pipe



## PROCUREMENT OF API 5L 3LPE COATED CS LINE PIPE



TENDER DOCUMENT NO:  
GSL/REPL/012/STPL

Date: 19/01/2023

partly coated with both epoxy and adhesive layers, shall be randomly selected by Company Representative for carrying out PQT as per Table 5.3.1. The procedure shall be considered qualified only when all tests as per Table 5.3.1 meet specified requirements. In case any of the tests fails to comply specified requirement, coating application procedure shall be re-qualified after necessary modifications. Company representative shall witness all tests.

All pipes coated during coating application procedure qualification shall be subjected to same visual and other inspection as required during production coating. Acceptance criteria shall be as specified under Section 5.4 of this specification.

Company reserves the right to conduct any or all the tests required for Coating Application Procedure Qualification through an independent laboratory or agency, at the cost of the Contractor, when in Company's opinion, the test results are deemed suspect. Company decision in this regard shall be final.

#### 4.2.8. PQT REPORT

Upon completion of the testing, the Contractor shall prepare and submit to the Company a detailed report covering operating and controlling parameters, inspection and test reports and material test certificates for Company approval. Only upon written approval from Company, the Contractor shall commence production coating.

#### 4.2.9. DISPOSAL OF TEST PIPES

On completion of coating application procedure qualification, the Contractor shall completely remove the coating on all remaining intact pipes coated for the purpose of procedure qualification and recycle them for production coating.

#### 4.2.10. PROCEDURE RE-QUALIFICATION

The coating application procedure shall be re-qualified in the event of, but not limited to, the following:

- Every time there is a change in the previously qualified procedure
- Every time there is a change in the epoxy/adhesive/polyethylene manufacturer and change in formulation of any of the material.
- Every time the coating yard is shifted from one location to another location/ critical equipment viz. induction heater, epoxy spray system, extruder etc. are changed.
- Any time when, in Company's opinion, the properties are deemed to be suspect during regular production tests.

### 4.3. PIPE SURFACE PREPARATION

#### 4.3.1. PRE-INSPECTION

Prior to cleaning operation, Contractor shall visually examine the pipes and shall ensure that



## PROCUREMENT OF API 5L 3LPE COATED CS LINE PIPE



TENDER DOCUMENT NO:  
GSL/REPL/012/STPL

Date: 19/01/2023

all defects, flats and other damages have been repaired or removed. The Contractor shall also remove marking stickers, if any, present within the pipe. Record shall be kept of such marking on the stickers to ensure traceability of pipe after coating.

### 4.3.2. REMOVAL OF SURFACE CONTAMINANTS

Any oil, grease, salt or other contaminants detrimental to the formation of a good coating bond or coating quality shall be removed prior to coating application. Contaminants may be removed by the use of non-oily solvents. Gasoline or kerosene shall not be used for this purpose. Visible oil and grease spots shall be removed by solvent wiping. Solvent cleaning shall be in accordance with SSPC-SP1. Steel surface shall be allowed to dry before abrasive cleaning.

### 4.3.3. PRE-HEATING

The pipe shall be preheated prior to blast cleaning to a temperature at least 5°C above the dew point to remove moisture and to raise slivers and other similar surface defects.

### 4.3.4. BLAST CLEANING

Prior to blasting operation, pipe ends shall be closed to prevent any abrasives and/or foreign material from entering the pipe's interior during blasting. Alternatively the Contractor may link the pipes suitably together to prevent the entry of any short/grit into the pipe. Pipe shall be handled in a manner so as to prevent any damage to bevels.



The external surface of the pipe shall be cleaned by dry abrasive blast cleaning unit(s). The abrasive blast cleaning unit(s) shall have an effective dust collection system to ensure total removal of dust generated during blast cleaning from the pipe surface. Traps, separators and filters shall be checked for condensed water and oil at the start of each shift and emptied and cleaned regularly. Metallic abrasives shall be continuously sieved to remove "fines" and "contaminants" and the quality checked at every four hours.

At no time shall the blast cleaning be performed when the relative humidity exceeds 85% or when the steel temperature is less than 5°C higher than the dew point, unless the pipes are preheated to a temperature of 65°C to 85°C.

The ratio of shots and grits in abrasives used for blast cleaning shall be such that the resulting surface profile does not appear dished and rounded when viewed under 30X magnification and specified anchor pattern is achieved.

Any abrasive and/or foreign material in the pipe shall be removed before further coating operations.

Immediately after the blast cleaning operation, all dust and grit shall be removed from inside of the pipe by a combination of air blast, brushing and vacuum cleaning.

	<b>PROCUREMENT OF API 5L 3LPE COATED CS LINE PIPE</b>	
TENDER DOCUMENT NO: GSL/REPL/012/STPL		<b>Date: 19/01/2023</b>

#### 4.3.5. REPAIR OF SURFACE IMPERFECTIONS

All surface defects visible on blast cleaned pipes such as slivers, scab, burns, laminations, weld spatters, gouges, scores, indentations, slugs or any other defect considered injurious to the coating integrity shall be removed by filing or grinding in consultation with Company Representative.

The method employed to remove surface defects shall not burnish or destroy the anchor pattern or contaminate the surface with oil or water. Pipe repairs by grinding resulting in ground areas more than 50 mm in diameter shall be re-blasted.

After any grinding or mechanical repairs, the remaining wall thickness shall be checked and any pipe having wall thickness less than 95% of specified wall thickness shall be kept aside and disposed of as per the instructions of Company Representative.

#### 4.3.6. ACCEPTANCE OF SURFACE PREPARATION

Upon Completion of the blasting operations, the Contractor's quality control supervisor shall inspect the pipes for their compliance to requirements specified below:

- The surface finish after blast cleaning shall conform to near white metal finish i.e. Sa 2 ½ of Swedish Standard SIS 055900.
- Anchor pattern/roughness profile shall be between 50 to 70 microns.
- Dust contamination shall be rating max. 2 as per ISO 8502-3.
- Salt content shall be less than 2 µg/cm<sup>2</sup>.

Pipes complying above requirements shall be accepted. Pipes that don't comply with above requirements shall be returned for re-blasting.

In order to ensure that pipes with improper surface preparation or unacceptable defects are not processed further, provisions shall be available to lift the pipes from inspection stand.

#### 4.3.7. CHEMICAL PRE-TREATMENT WITH CHROMATE SOLUTION

Following completion of abrasive blast cleaning, all pipe surfaces shall be chemically pretreated with a 10% (+2%) strength chromate solution.

The Contractor shall provide data sheets and supporting documentation for the chemical to be used. The documentation shall verify that the chemical is suitable for the treatment of line pipe prior to the application of the specific fusion bonded epoxy powder being applied and the final coating will meet fully the requirements of this specification.

The chemical pre-treatment shall be applied fully in accordance with the chemical suppliers' instructions and in a manner that ensures 100% uniform coverage of the pipe surface without



## PROCUREMENT OF API 5L 3LPE COATED CS LINE PIPE



TENDER DOCUMENT NO:  
GSL/REPL/012/STPL

Date: 19/01/2023

introducing surface contamination.

The Contractor shall check that the concentration of the chemical pre-treatment solution remains within the range recommended by the chemical manufacturer for the pipe coating process. The concentration shall be checked at the make-up of each fresh solution and once per hour, using a method approved by the chemical manufacturer. The Contractor shall also ensure that the chemical pre-treatment solution remains free from contamination at all times. Recycling of chemical pre-treatment solution is not permitted.

The Contractor shall ensure that the temperature of the substrate is maintained between 40°C and 80°C and the chromate solution temperature does not exceed 60° or as recommended by the manufacturer.

The chromate coating shall be smooth, even, free from runs, drips or excessive application and lightly adherent with no flaking of the coating. The chromate coated steel must be thoroughly dried immediately after application and shall be achieved by boiling off any residual solution on the surface.

#### 4.3.8. ELAPSED TIME FOR COATING APPLICATION

Maximum allowable elapsed time between completion of the blasting operations and commencement of pipe heating for coating application shall be as given below:



Relative Humidity %	Maximum Allowable Elapsed Time
>80	2 hours
70 to 80	3 hours
<70	4 hours

Pipes that have exceeded the allowable elapsed time shall be returned for complete re- blasting. Any pipe showing flash rusting shall be re-blasted even if the above conditions have not been exceeded.

Pipe handling between abrasive blasting and pipe coating shall not damage the surface profile achieved during blasting. Any pipe having damage to the surface exceeding 200mm<sup>2</sup> shall be sent for re-blasting.

#### 4.4. COATING APPLICATION

The external surface of the cleaned pipe conforming to clause 4.3 of this specification shall be immediately coated with 3-layer extruded polyethylene coating in accordance with the procedures approved by Company, relevant standards and this specification. In general the

	<b>PROCUREMENT OF API 5L 3LPE COATED CS LINE PIPE</b>	
TENDER DOCUMENT NO: GSL/REPL/012/STPL		<b>Date: 19/01/2023</b>

procedure shall be as follows:

**4.4.1. PIPE HEATING**

- a. Immediately prior to heating of pipe, all dust and grit shall be removed from inside of the pipe by combination of air blast, brushing and vacuum cleaning. Suitable arrangement shall be made to protect the bevel ends from getting damaged during the coating operation
- b. Induction heater or gas fired heating shall be used for heating the pipe. The method shall be capable of maintaining uniform temperature along the total length of the pipe, and shall be such that it shall not contaminate the surface to be coated. In case of induction heating, appropriate frequency shall be used to ensure 'deep heating' and intense skin heating is avoided. Gas fired heating system shall be well adjusted so that no combustion products are deposited on the steel surface. This shall be demonstrated on bare pipes prior to start of PQT. Oxidation of the cleaned pipe surfaces prior to coating (in the form of blueing or other apparent oxide formation) is not acceptable.
- c. External surface of the pipe shall be heated to about 190 °C or within a temperature range (min. to max.) as recommended by the powder manufacturer. Required pipe temperature shall be maintained as it enters the coating chamber.
- d. Temperature of the pipe surface shall be continuously monitored & recorded by using suitable instruments such as infrared sensors, contact thermometers, thermocouples etc. The recording method shall allow correlating each line pipe. The monitoring instrument shall be able to raise an alarm/activate audio system (hooter) in the event of tripping of induction heater/ gas fired heater or in the event of pipe temperature being outside the range recommended by the manufacturer. Any deviation from the application temperature range recommended by manufacturer shall be rectified. If immediate rectification is not feasible, the production shall be stopped until cause of deviation has been removed. Any pipe coated during the duration of temperature deviation shall be identified by marking and rejected. Such rejected pipes shall be stripped, re-cleaned and recoated.
- e. Temperature measuring & monitoring equipment shall be calibrated twice every shift and/or as per Company Representative's instruction.
- f. Contractor shall ensure that pipe surface emissivity variations are minimized during pipe heating. To avoid significant variance, more than once blasted joints should be coated at the same time and not mixed with joints blasted only once

**4.4.2. APPLICATION OF EPOXY, ADHESIVE AND POLYETHYLENE**

The heated pipe surface shall be applied with following coating layers:

	<b>Minimum Coating Thickness In mm</b>		
			<b>Total [3, 4]</b>

**PROCUREMENT OF API 5L 3LPE COATED CS LINE PIPE**TENDER DOCUMENT NO:  
GSL/REPL/012/STPL**Date: 19/01/2023**

<b>Specified Pipe OD, Inches (mm)</b>	<b>FBE [1]</b>	<b>Adhesive [2]</b>	<b>PE [2,3]</b>	<b>Normal Type (n)</b>	<b>Reinforced Type (v)</b>
Up to 4½ (114.3)	0.2	0.2	1.45	1.85	2.55
Over 4½ (114.3) Up to 10¾ (273.1)	0.2	0.2	1.65	2.05	2.75
Over 10¾ (273.1) to below 20 (508.0)	0.2	0.2	1.85	2.25	2.95
From 20 (508.0) to below 32 (813.0)	0.2	0.2	2.15	2.55	3.25
From 32 (813.0) and above	0.2	0.2	2.65	3.05	3.75



## PROCUREMENT OF API 5L 3LPE COATED CS LINE PIPE



TENDER DOCUMENT NO:  
GSL/REPL/012/STPL

Date: 19/01/2023

### Notes:

1. Epoxy shall be applied by electrostatic spray method the maximum thickness shall not exceed the epoxy thickness specified by epoxy powder manufacturer.
2. Grafted co-polymer adhesive and polyethylene layers shall be applied by extrusion.
3. In case HDPE is used as top coat, 10% reduction in PE top coat thickness is permissible
4. Unless indicated otherwise in Purchase Order, total thickness corresponding to Normal Type (n) coating shall be applicable.

### EPOXY APPLICATION

Epoxy powder shall be sprayed on to heated pipe using electrostatic spray technique. Only dry air, free of oil and moisture shall be used in the coating chamber and epoxy spraying system. Dew point of air supplied to epoxy spray/recycling system shall be at least - 40°C.

Air pressure in the epoxy spray guns shall be controlled, continuously monitored and recorded at least four times per working shift (maximum 12 hours). The air pressure shall be controlled within the limits established during coating application procedure qualification. The monitoring system shall be able capable of raising an alarm / activate audio system (hooter) in the event of change in air pressure beyond the set limits. All pipescoated during the duration of air pressure deviation beyond set limits shall be stripped andrecoated.

The recycled epoxy powder mixing with fresh epoxy powder shall be permitted subject to following conditions:

- Quality of recycled epoxy powder has been established to be acceptable during coating application procedure qualification.
- Proportion of the recycled epoxy powder in the working mix does not exceed that established during coating application procedure qualification or 20% at a time, whichever is less.
- Quality of the recycled powder is checked minimum once per working shift (maximum 12 hours) by visual examination, thermal analysis & moisture content testing and properties of recycled epoxy are established to be within manufacturer specified range.

### ADHESIVE AND POLYETHYLENE LAYER APPLICATION

Extruded adhesive layer shall be applied before gel time of the epoxy coating has elapsed and within the window recommended by the manufacturer. The Contractor shall establish, to the satisfaction of the Company Representative, that the adhesive is applied within the gel time window of epoxy and at the temperature recommended by the adhesive manufacturer. The Contractor shall state the minimum and maximum time interval between epoxy and adhesive application at the proposed pre-heat temperature and line speed.

Extruded polyethylene layer shall be applied over the adhesive layer within the time limit established during PQT stage and within the time/temperature range recommended by the



## PROCUREMENT OF API 5L 3LPE COATED CS LINE PIPE



TENDER DOCUMENT NO:  
GSL/REPL/012/STPL

Date: 19/01/2023

manufacturer. The extrusion temperatures of the adhesive and polyethylene shall be continuously recorded. The monitoring instruments shall be independent of the temperature control equipment. The instruments shall be calibrated prior to start of each shift.

The extrusion temperatures of the adhesive and polyethylene shall be continuously monitored and recorded at least four times per working shift (maximum 12 hours). The monitoring instruments shall be independent of the temperature control equipment. The instruments shall be calibrated from NABL approved laboratory.

Contractor shall ensure that there is no entrapment of air or void formation along the seam weld (where applicable) during application of coating.

Resultant coating shall have a uniform gloss and appearance and shall be free from air bubbles, wrinkles, irregularities, discontinuities, separation between layers of polyethylene & adhesive, etc.

The coated pipe shall be subsequently quenched and cooled in water for a period that shall sufficiently lower the temperature of pipe coating to allow handling and inspection.

### 4.4.3. COATING CUT BACK

Coating and/or adhesive shall terminate 120 mm +20 / -0 mm from pipe ends. Contractor shall adopt mechanical brushing for termination of the coating at pipe ends. Edge of the coating shall be shaped to form a bevel angle of 30° to 45°.

### 4.4.4. REJECTION OF COATING

Failure of the Contractor to comply with above coating application requirements including approved coating application procedure shall result in rejection of the coating applied and the Contractor shall remove the coating from such coated pipes and recycle the pipes through entire coating process

## 5.0 INSPECTION AND TESTING

### 5.1. GENERAL

The Contractor shall establish and maintain such quality assurance system as are necessary to ensure that goods or services supplied comply in all respects with the requirements of this specification. The minimum inspection and testing to be performed shall be as indicated subsequently herein. Pipes with unacceptable coating shall be stripped and recycled.

### 5.2. TESTING OF MATERIALS

One week prior to use, Contractor shall carry out following tests on samples randomly drawn by Company Representative from each batch of raw materials proposed to be used

for coating application in the next week’s production to establish compliance with coating material manufacturer’s test certificates.

<b>Table 5.2 : Coating Material Testing</b>		
<b>Material</b>	<b>Test</b>	<b>Test method and acceptance criteria</b>
Epoxy Powder	Gel Time, Cure Time, Moisture Analysis and Thermal Characteristics (Tg1,Tg2 ,ΔH)	As per CSA standard Z245.20.18
Adhesive	Specific Gravity, Melt Flow Rate(Condition 190/2.16), Vicat Softening Point	As per Section 3.2.3 (b) of this specification
Polyethylene	Melt Flow Rate(Condition 190/2.16) Specific Gravity, Vicat Softening Point, Moisture Content, Oxidative Induction time	As per Section 3.2.4 (e) of this specification

In case of failure of any of the above tests, batch of material from which samples are drawn shall be tested for all properties specified under section 3.2.1, 3.2.2 and 3.2.3 (except ESCR) of this specification. If all tests result comply with required properties, the batch shall be accepted for coating. If any of the tests fail to comply with required properties, batch of material that fails to comply shall be rejected.

**5.3. TESTING OF COATING**

Testing requirements and frequency of testing during PQT and production coating shall be as per Table 5.3.1 and Table 5.3.2 respectively. The method of testing, acceptance criteria and re-testing shall be as described hereinafter.

**Table 5.3.1 : Testing Requirement for Coating Procedure Qualification**



Sl. No	Test	Testing Frequency	Test Method and Acceptance Criteria	Remarks
a	Degree of Cure	Two Test Pipe	Section 5.3.1	Note 1
b	Adhesion Tests	One Test Pipe	Section 5.3.2	Note 2
c	2.5° Flexibility Test	One Test Pipe	Section 5.3.3	Note 2
d	Cross Section and Interface Porosity Test	One Test Pipe	Section 5.3.4	Note 2
e	Bond Strength	Three Test Pipes	Section 5.3.5	Note 3
f	Impact Strength	Three Test Pipes	Section 5.3.6	
g	Indentation Hardness	All Test Pipes	Section 5.3.7	Note 4
h	Percentage Elongation at Failure	All Test Pipes	Section 5.3.8	Note 4
i	Air Entrapment Test	All Test Pipes	Section 5.3.10	Note 4
j	<b>Thickness Measurements</b>			
	Epoxy Layer	One Test Pipe	Section 5.3.11	Note 2
	Adhesive Layer	One Test Pipe		Note 2
Total Coating Thickness	All Coated Pipes	Note 5		
k	Holiday Inspection	All coated Pipes	Section 5.3.12	Note 5
l	<b>Cathodic Disbondment Test</b>			
	30 days test at (+) 65° C	One Test Pipe	Section 5.3.9	Note 3, 6
48 hour test at (+) 65° C	One Test Pipe			

**Notes:**

- Test shall be carried out on one partly coated test pipe one test pipe coated with all three layers.

2. Test shall be carried out on test pipe partly coated pipe
3. Test shall be carried out on test pipes coated with all three layers.
4. Test shall be carried out on all test pipes coated with all three layers
5. Test shall be carried out on all pipes coated with all three layers.
6. Both 30 days and 48 hour tests shall be carried out for a particular material combination and pipe diameter. In case results for 30 days test are satisfactory, subsequent coating application procedure qualification for different pipe size with same coating material combination, 48 hours test shall be acceptable

<b>Table 5.3.2 : Testing Requirement During Production Coating</b>				
Sl. No	Test	Testing Frequency	Test Method and Acceptance Criteria	Remarks
a	Degree of Cure	One Pipe/Shift	Section 5.3.1	Note 1, 2
b	Adhesion Tests	One Pipe/ Shift	Section 5.3.2	Note 1, 2
c	Bond Strength	One out of 25 Pipes	Section 5.3.5	Note 1, 2
d	Impact Strength	One Pipe/Shift	Section 5.3.6	Note 1, 2
e	Indentation Hardness	One Pipe/Shift	Section 5.3.7	Note 1, 2
f	Air Entrapment Test	One out of 25 Pipes	Section 5.3.10	Note 1, 2
<b>Thickness Measurements</b>				
g	Epoxy Layer	Once in the beginning of Shift or whenever plant restart after stoppage	Section 5.3.11	Note 1, 4
	Adhesive Layer			
	Total Coating Thickness	All Pipes		
h	Holiday Inspection	All Pipes	Section 5.3.12	Note 1, 4
i	Cathodic Disbondment Test 48 hour test at (+) 65° C	Once per week or each batch of epoxy used whichever is early	Section 5.3.9	Note 1, 3

	<b>PROCUREMENT OF API 5L 3LPE COATED CS LINE PIPE</b>	
TENDER DOCUMENT NO: GSL/REPL/012/STPL		<b>Date: 19/01/2023</b>

**Notes:**

- 1 Working shift shall be maximum 12 hours.
- 2 In case the test fails to comply the specified requirement, preceding and succeeding coated pipes shall be tested. If both pipes pass the test, then the remainder of the coated pipes in the lot shall be accepted. If tests on any one of the two pipes fail to meet the specified requirements then either all pipes shall be individually tested or entire lot rejected at the option of the Contractor. All rejected coated pipes shall be stripped and re-coated.
- 3 In case of failure of test, the test shall be repeated using two additional samples taken from same end of pipe. In case both test pass, the pipes shall be accepted. If one or both tests fail all pipes coated after the previous acceptable test and prior to next acceptable test shall be reject. All rejected coated pipes shall be stripped and re- coated.
- 4 Pipes not meeting the specified requirements shall be rejected. All rejected coated pipes shall be stripped and re-coated.

**5.3.1. DEGREE OF CURE**

The samples for epoxy testing shall be taken from cut back area, separated from adhesive and polyethylene layer by silicon coated sulphite paper, in case of fully coated pipe and from epoxy coated section of pipe partly coated pipe during application procedure qualification.

Epoxy samples (minimum 4 no.) shall be removed from the coated pipe using hammer and cold chisel and the samples shall be taken for cure test using DSC procedure. Care shall be taken to remove the samples of full film thickness avoiding inclusion of steel debris. Glass transition temperature differential ( $\Delta T_g$ ) and % cure ( $\Delta H$ ) shall comply with the requirements of Section 3.2.5 (i).

**5.3.2. ADHESION TESTS**

For Pre-Qualification Testing (PQT)

Adhesive test (24 hrs or 48 hrs) shall be carried out on epoxy coated pipe. Test method, no. of test specimen and acceptance criteria shall comply CSA Z.245.20-18, Table 4.

For PQT and Regular Production Testing

Adhesion of epoxy layer shall be determined at ambient temperature by the “St Andrews Cross” method i.e. by cutting two straight lines through the epoxy layer with a sharp knife at the cut-back portion of the pipe from which the Degree of Cure test has been carried out. The incisions shall intersect at an angle of 30°/150°. The epoxy coating shall resist Dis-bondment from the steel when attempts are made to flick/lift the coating from the 30° angle with a sharp knife.

**5.3.3. 2.5° FLEXIBILITY TEST**



## PROCUREMENT OF API 5L 3LPE COATED CS LINE PIPE



TENDER DOCUMENT NO:  
GSL/REPL/012/STPL

Date: 19/01/2023

Samples for 2.5° Flexibility test shall be taken as indicated under Section 5.3.1. 2.5° Flexibility test shall be carried out at a test temperature of 0°C. Test method, number of test specimen and acceptance criteria shall comply CSA Z.245.20-18, Table 4.

### **5.3.4. CROSS-SECTION & INTERFACE POROSITY TEST**

Samples for cross section porosity and interface porosity test shall be taken as indicated under Section 5.3.1. Cross section porosity and interface porosity test method, number of test specimen and acceptance criteria shall comply CSA Z.245.20-18, Table 4.

### **5.3.5. BOND STRENGTH TEST**

One test shall be performed at cut back portion at each end and one in the middle of test pipe for each specified temperature (i.e. total 6 tests per pipe).

Test method and acceptance criteria shall be as per Section 3.2.5, Sl. No. (a) Of this specification.

### **5.3.6. IMPACT STRENGTH TEST**

Test method and acceptance criteria shall be as per Section 3.2.5, Sl. No. (b) of this specification.

A minimum of 30 impacts, located equidistant along the length of test pipe, shall be performed. Immediately after testing, the test area shall be subjected to holiday detection. The pipe shall be rejected if any holiday is noted in the test area.

### **5.3.7. INDENTATION HARDNESS**

Test method and acceptance criteria shall be as per Section 3.2.5, Sl. No. (c) of this specification.



One test shall be performed at cut back portion at each of test pipe for each specified temperature (i.e. total 4 tests per pipe).

### **5.3.8. PERCENTAGE ELONGATION AT FAILURE**

Six samples from each test pipe shall be tested in accordance with Section 3.2.5, Sl. No. (d) of this Specification. Only one sample per pipe may fail.

### **5.3.9. CATHODIC DISBONDMENT TEST**

Test shall be carried out on pipe having all three layers as per Section 3.2.5, Sl. No. (h) of this Specification.

	<b>PROCUREMENT OF API 5L 3LPE COATED CS LINE PIPE</b>	
TENDER DOCUMENT NO: GSL/REPL/012/STPL		<b>Date: 19/01/2023</b>

### **5.3.10. AIR ENTRAPMENT TEST**

Air entrapment test shall be carried out by examining strips of coating removed from coated pipe under 30X magnification hand held microscope for presence of voids.

Strips shall be obtained from the cut back area of pipe. Additional strips shall be taken from weld area when applicable. Alternatively strips from bond strength tests may be used. Bond strength strip shall be viewed from the side and at the failure interface. Utility knife shall be used to cut the edge of the coating to a 45° angle at pipe and cut surface viewed under microscope. Similar examination shall be done in the coating strip obtained from cutback area. The polyethylene and adhesive layers shall have no more than 10% of the observed area taken up with air entrapment (porosity or bubbles). Air entrapment shall not occupy more than 10% of the thickness in each case. Bubbles shall not link together to provide a moisture path to the epoxy layer.

### **5.3.11. THICKNESS MEASUREMENTS EPOXY AND ADHESIVE LAYER**

Epoxy and adhesive layer thickness shall be checked at one-meter spacing at 3, 6, 9 and 12 o'clock positions. All readings must meet the minimum thickness specified under section 4.4.3. Epoxy and adhesive layer thickness shall be measured on pipe partly coated with epoxy and partly coated with epoxy and adhesive.

### **TOTAL COATING THICKNESS**

The coating thickness shall be determined by taking at least 10 measurements at locations uniformly distributed over the length and periphery of each pipe. In case of welded pipes, five of the above readings shall be made at the apex of the weld seam, uniformly distributed over the length of the coated pipe.

### **5.3.12. HOLIDAY DETECTION**

Each coated pipe length shall be checked over 100% of coated surface by means of a "holiday detector" of a type approved by Company for detecting holidays in the finished coating.

The holiday detector shall be a low pulse D.C. full circle electronic detector with audible alarm and precise voltage control complying with Annex. E of DIN 30670:2012.

Holiday detector shall be calibrated at least once every 4 hours of production. Contractor shall have necessary instruments or devices for calibrating the holiday detector.

Travel speed during holiday inspection shall be as recommended by the manufacturer of holiday detector.

The holiday detector set voltage and acceptance criteria shall be as follows:



## PROCUREMENT OF API 5L 3LPE COATED CS LINE PIPE



TENDER DOCUMENT NO:  
GSL/REPL/012/STPL

Date: 19/01/2023

### **ONLY EPOXY / EPOXY AND ADHESIVE COATED PIPES**

Only epoxy coated section shall be subject to holiday inspection at a test voltage set to exceed 5V / micron of epoxy thickness. Section of pipe coated with both epoxy and adhesive shall be tested at a voltage of 25kV. No holidays are permitted.

### **PIPE COATED WITH ALL THREE LAYERS**

The coated pipe shall be inspected with the holiday detector set at minimum 25kV.

Coated pipe shall be rejected if more than one (1) holiday & area more than 100 cm<sup>2</sup> in size are detected in its length attributable to coating process.

Coated pipe with a single holiday of an area equal or less than 100cm<sup>2</sup> shall be accepted after repair.

In case more than 10% of coated pipes per shift production are rejected on account of holidays, the Contractor shall stop production and make a detailed investigation and submit a report to the Company representative on the probable cause(s) for the holidays. Production shall restart only after such a cause has been rectified.

#### **5.4 REPAIR OF COATING DAMAGES DUE TO TESTING**

Damages occurring to pipe coating during the above tests shall be repaired in accordance with the Section 7 of this specification

#### **5.5 VISUAL INSPECTION**

Pipes shall be visually inspected throughout the coating process from incoming bare pipe to finished coated pipes as described herein below:

##### **5.5.1. INSPECTION OF INCOMING PIPES**

All incoming pipes, before any coating application process starts, shall be examined visually for any surface defects such as split seams, dents, gouges, slivers or other imperfections that would make the pipe unsuitable for use. Pipes with such defects shall be repaired in accordance with approved procedure before they are released for further processing.

##### **5.5.2. INSPECTION OF BLAST CLEANED PIPES**

Surface of pipes after blast cleaning shall be examined for any defects injurious to coating application.

Surface profile shall be examined by using suitable instrument such as surface profile depth gauge for compliance to anchor pattern requirements. In addition the pipe surface shall be checked for the degree of cleanliness (Sa 2½), degree of dust and shape of profile.



## PROCUREMENT OF API 5L 3LPE COATED CS LINE PIPE



TENDER DOCUMENT NO:  
GSL/REPL/012/STPL

Date: 19/01/2023

In addition, inside surface of the pipe shall also be visually examined for presence of any foreign material or shots and grit (free or embedded/sticking to pipe inside surface). Any foreign material or shots/grit present in the pipe shall be completely removed by suitable means (mechanical brush, high pressure air jets, by tilting of pipe etc.).

The blast-cleaned surface shall not be contaminated with dirt, dust, metal particles, oil, water or any other foreign material, nor shall the surface or its anchor pattern be scarred or burnished.

### 5.5.3. INSPECTION OF COATED PIPES

Each coated pipe shall be visually checked for imperfections and irregularities of the coating. The resultant coating shall have a uniform appearance with natural colour & gloss and shall be free from air bubbles, blisters, wrinkles, scratches, engravings, cuts, swellings, disbanded zones, tears, voids, irregularities, discontinuities and separation between layers of FBE/adhesive/PE. Special attention shall be paid to the areas adjacent to the weld seam (if applicable). Coating surface shall not be physically damaged or contaminated with any foreign material such as dirt, metal particles, coating debris during application, curing, and handling process.

### 5.6 SOLUBLE SALT MEASUREMENTS

Chlorides and ferrous salts present on pipe surface that can affect the coating performance shall be monitored prior to application of coating.

After blast cleaning, all pipes shall be tested for salt contamination. One test shall be carried out at each end of each pipe using salt meter (SCM 400 or approved equivalent). The acceptance criteria shall be  $2 \mu\text{g}/\text{cm}^2$ . Any pipe having salt contamination exceeding  $2 \mu\text{g}/\text{cm}^2$  shall be treated by phosphoric acid wash followed by de-ionized water wash in accordance with the recommendations of the manufacturer. The Contractor shall submit a detailed procedure for phosphoric acid wash for Company approval.

### 6.0 HANDLING, TRANSPORTATION AND STORAGE

- 6.1.** The Contractor shall be fully responsible for the pipe and for the pipe identification marking from the time of "taking over" of bare pipe from Company until such time that the coated line pipes are 'handed over' and/or installed in the permanent installation as the case may be according to the provisions of the CONTRACT.

At the time of "taking over" of bare pipes Contractor shall inspect and record all the relevant details referred above including pipe defects in the presence of Company. All pipes shall be checked for bevel damages, weld seam height, dents, gouges, corrosion and other damages. Company Representative shall decide whether pipe defects / damages are suitable for repair. Damage to the pipes that occur after the Contractor has taken delivery such as dents, flats, or damage to the weld ends shall be cut off or removed and pipes re-



## PROCUREMENT OF API 5L 3LPE COATED CS LINE PIPE



TENDER DOCUMENT NO:  
GSL/REPL/012/STPL

Date: 19/01/2023

bevelled and repaired again as necessary. The cost of this work, as well as that of the pipelost in cutting and repair shall be to the Contractor's account. All such works shall be carried out after written approval of the Company. Any reduction in length shall be indicated in the Contractor's pipe tracking system.

- 6.2.** The Contractor shall unload, load, stockpile and transport the bare pipes within the coating plant(s) using suitable means and in a manner to avoid damage to pipes.

The Contractor shall stockpile the bare pipes at the storage area of the coating plant. The Contractor shall prepare and furnish to Company a procedure/calculation generally in compliance with API RP-5L1 for stacking of pipes of individual sizes, which shall be approved by Company prior to commencement.

- 6.3.** The Contractor shall load, unload, transport and stockpile the coated pipes within the coating plant using approved suitable means and in a manner to avoid damage to the pipe and coating. The Company shall approve such procedure prior to commencement of work.

- 6.4.** Coated pipes may be handled by means of slings and belts of proper width (minimum 60 mm) made of non-abrasive/non-metallic materials. In this case, pipes to be stacked shall be separated row by row to avoid damages by rubbing the coated surface in the process of taking off the slings. Use of round sectional slings is prohibited. Forklifts may be used provided that the arms of the forklift are covered with suitable pads, preferably rubber.

- 6.5.** Bare/coated pipes at all times shall be stacked completely clear from the ground, at least 300 mm, so that the bottom rows of pipes remain free from any surface water. The pipes shall be stacked at a slope so that driving rain does not collect inside the pipe. Bare/coated pipes may be stacked by placing them on ridges of sand free from stones and covered with a plastic film or on wooden supports provided with suitable cover. This cover can be of dry, germ free straw covered with plastic film, otherwise foam rubber may be used. The supports shall be spaced in such a manner as to avoid permanent bending of the pipes.

Stacks shall consist of limited number of layers such that the pressure exercised by the pipe's own weight does not cause damages to the coating. Contractor shall submit calculations for Company approval in this regard. Each pipe section shall be separated by means of spacers suitably spaced for this purpose. Stacks shall be suitably secured against falling down and shall consist of pipe sections having the same diameter and wall thickness. The weld seam of pipes shall be positioned always in a manner so as not to touch the adjacent pipes.

The ends of the pipes during handling and stacking shall always be protected with bevel protectors or End Caps.

- 6.6.** The lorries used for transportation shall be equipped with adequate pipe supports having as many round hollow beds as there are pipes to be placed on the bottom of the lorry bed. Total width of the supports shall be at least 5% of the pipe length and min. 2 no. support shall be



## PROCUREMENT OF API 5L 3LPE COATED CS LINE PIPE



TENDER DOCUMENT NO:  
GSL/REPL/012/STPL

Date: 19/01/2023

provided. These supports shall be lined with a rubber protection and shall be spaced in a manner as to support equal load from the pipes the rubber protection must be free from all nails and staples where pipes are in contact. The second layer and all following layers shall be separated from the other with adequate number of separating layers of protective material such as straw in plastic covers or mineral wool strips or equivalent, to avoid direct touch between the coated pipes.

All stanchions of Lorries used for transportation shall be covered by non-abrasive material like rubber belts or equivalent. Care shall be exercised to properly cover the top of the stanchions and other positions such as reinforcement of the truck body, rivets, etc. to prevent damage to the coated surface. Slings or non-metallic straps shall be used for securing loads during transportation. They shall be suitably padded at the contact points with the pipe

- 6.7.** Materials other than pipes and which are susceptible of deteriorating or suffering from damages especially due to humidity, exposure to high thermal excursions or other adverse weather conditions, shall be suitably stored and protected. Deteriorated materials shall not be used and shall be replaced at Contractor's expenses. These materials shall always be handled during loading, unloading and storage in a manner so as to prevent any damage, alteration and dispersion. When supplied in containers and envelopes, they shall not be dropped or thrown, or removed by means of hooks, both during the handling operations till their complete use. During unloading, transport and utilization, any contact with water, earth, crushed stone and any other foreign material shall be carefully avoided.

Contractor shall strictly follow Manufacturer's instructions regarding storage temperature and methods for volatile materials that are susceptible to change in properties and characteristics due to unsuitable storage. If necessary the Contractor shall provide for a proper conditioning.

- 6.8.** In case of any marine transportation of bare/coated line pipes involved, the same shall be carried out in compliance with API RP 5LW. Contractor shall furnish all details pertaining to marine transportation including drawings of cargo barges, storing/stacking, sea fastening of pipes on the barges/marine vessels to the company for approval prior to undertaking such transportation works. In addition contractor shall also carry out requisite analyses considering the proposed transportation scheme and establish the same is safe and stable. On-deck overseas shipment shall not be allowed.

## **7.0 REPAIR OF COATING AND FINAL ACCEPTANCE**

### **7.1. COATING REPAIR**

Contractor shall submit and qualify a comprehensive repair procedure for carrying out repairs of defects. The procedure shall be subject to approval of Company. The repair procedure shall cover application over bare as well as over coated pipe surfaces.

Testing of repairs shall be in the same form as testing production coating. All repairs shall



## PROCUREMENT OF API 5L 3LPE COATED CS LINE PIPE



TENDER DOCUMENT NO:  
GSL/REPL/012/STPL

Date: 19/01/2023

result in a coating thickness no less than the parent coating thickness.

Defects, repairs and acceptability criteria shall be as follows:

- Pipes showing porosities or very small damage not detected during holiday test and having a surface area less than 0.5cm<sup>2</sup> or linear damage (cut) of less than 3 cm, and does not expose bare steel, shall be repaired by stick using material of same quality as coating.
- Damage to coating caused during handling such as scratches, cuts, dents, gouges, not detected during holiday test, having a total reduced thickness on the damaged portion of not less than 2.0 mm and an area not exceeding 20 cm<sup>2</sup> shall be repaired by applying a heat shrink patch without exposing bare metal surface.
- Defects exceeding the sizes as indicated above or any holidays of size less than 300 mm shall be repaired using heat shrink patch. The defect area shall be exposed up to bare metal prior to application of heat shrink patch
- Defects exceeding the above and in number not exceeding 2 per pipe and linear length not exceeding 500 mm shall be repaired using heat shrinkable sleeves of HTLP 80 or equivalent.
- Pipes with bigger damage shall be stripped and recoated.
- In case of coating defect close to coating cut back, Contractor shall remove the coating throughout the entire circumference of the pipe down to the steel surface and increase the coating cut back length. Now if the coating cut back exceeds 140 mm of linear length of pipe then the coating shall be repaired by the use of heat shrink sleeves thereby making up the coating cut back length of 120 mm.

Notwithstanding the above, if any defect exceeds 70 mm from the original coating cut back length, the entire coating shall be removed and the pipe shall be recycled through the entire coating procedure.

Irrespective of type of repair, the maximum numbers of repair of coating shall be as follows:

- Holiday repair of size  $\leq 100$  cm<sup>2</sup> attributable to process of coating application shall be maximum one number per pipe.
- In addition to the above, defects to be repaired by heat shrink patch/sleeve shall be maximum 2 (two) per pipe.

Defects exceeding the above limits shall cause pipe coating rejection, stripping and recoating.

The above is exclusive of the repairs warranted due to testing as per this specification.

All repairs carried out to coating for whatever reason shall be to the account of Contractor. Cosmetic damages occurring in the polyethylene layer only need not be repaired by exposing up to steel surface, as deemed fit by the Company Representative. In any case the Contractor shall establish his material, methods and procedure of repair that result in an acceptable quality of product by testing and shall receive approval from Company prior to use.

Testing of repairs shall be in the same form as testing coating. All repairs shall result in a coating thickness no less than the parent coating thickness. Contractor shall test repairs to



## PROCUREMENT OF API 5L 3LPE COATED CS LINE PIPE



TENDER DOCUMENT NO:  
GSL/REPL/012/STPL

Date: 19/01/2023

coating as and when required by Company.

### 8.0 MARKING AND PIPE IDENTIFICATION

The Contractor shall preserve pipe identity by maintaining the identity of each joint of pipe. Final markings shall be applied on the outside wall of the pipe at a maximum distance of 500 mm from the end. The marking shall indicate, but not be limited to, the following information:

- i. Pipe number, Heat number.
- ii. Coated pipe number.
- iii. Colour band
- iv. Diameter, wall thickness, weight and length.
- v. Barcode labels shall be fixed on one end at inside of Pipes.
- vi. Any other information considered relevant by Purchaser.
- Vii. Pipe manufacturer's name
- Viii. Inspection Marks /Punch

Manufacturer shall obtain prior approval from Company for the marking procedure to be adopted.

### 9.0 PRODUCTION REPORT

Contractor shall prepare and maintain a detailed production reporting system, which shall provide a detailed history of each pipe length. The Company shall provide pipe manufacturing data files (in MS Excel format) to the Contractor. The pipe manufacturer data files shall, as a minimum, the contain the following data:-

- Pipe number
- Heat number
- Pipe grade
- Diameter
- Length
- Wall thickness
- Pipe weight

Prior to acceptance of the pipe at the wharf, the Contractor in the presence of the Company Representative shall identify and record any minor defects, such as dents, flats or damaged bevels, found during the acceptance inspection. The Contractor shall be responsible for any subsequent damage to the pipe.

The Contractor shall update the pipe data files received from pipe manufacturer by adding coating data. As a minimum, following data shall be added.

- Details of defect repairs, if any, carried out on the bare pipes received
- Coating material batch numbers



## PROCUREMENT OF API 5L 3LPE COATED CS LINE PIPE



TENDER DOCUMENT NO:  
GSL/REPL/012/STPL

Date: 19/01/2023

- Pre-qualification tests for raw materials
- Coating procedure qualification tests
- Coating material balance
- Coated pipe sampling details
  
- Coated pipe test results
- Coated pipe weight
- Coating defects
- Coating repairs
- Hold points
- Rejected pipe

### 10.0 QUALITY ASSURANCE

- 10.1.** The Contractor shall have established within his organization and, shall operate for the contract, a documented Quality System that ensures that the requirements of this specification are met in all aspects. The Quality System shall be based upon ISO 9001/2 or equivalent.
- 10.2.** The Contractor shall have established a Quality Assurance Group within its organization that shall be responsible for reviewing the Quality System and ensuring that it is implemented.
- 10.3.** The Contractor shall submit the procedures that comprise the Quality System to the Company for agreement.
- 10.4.** The Contractor's Quality System shall pay particular attention to the control of Suppliers and Sub-contractors and shall ensure that the requirements of this specification are satisfied by the Suppliers and Sub-contractors operating Quality system in their organization.
- 10.5.** The Contractor shall, prior to the commencement of work, prepare and issue a Quality Plan for all of the activities required satisfying the requirements of this specification. The plan shall include any sub-contracted work, for which the sub-contractors Quality Plans shall be submitted. The plan shall be sufficiently detailed to indicate sequentially for each discipline the requisite quality control, inspection, testing and certification activities with reference to the relevant procedures and the acceptance standards.
- 10.6.** The Contractor's Quality system and associated procedures may, with due notice, be subject to formal audits. The application of quality control by the Contractor will be monitored by the Company Representatives who will witness and accept the inspection, testing and associated work required by this specification.

**PROCUREMENT OF API 5L 3LPE COATED CS LINE PIPE**TENDER DOCUMENT NO:  
GSL/REPL/012/STPL**Date: 19/01/2023****ANNEXURE-I****LIST OF ACCEPTABLE COMBINATIONS OF COATING MATERIALS**

The following combinations of coating materials are considered acceptable. In case any of the combinations listed below are offered, details regarding properties of the offered materials need not be furnished with bid. However, In the event of award of contract, Contractor shall furnish the combination(s) proposed and re-confirmation of compatibility of the proposed combination (s) from the raw materials Manufacturers.

<b>Epoxy Powder (Manufacturer)</b>	<b>Adhesive (Manufacturer)</b>	<b>PE Compound (Manufacturer)</b>
CORRO-COAT EP-F 2001(JOTUN)	FUSABOND 158D (DUPONT)	SCLAIR 35 BP HDPE (NOVACOR)
CORRO-COAT EP-F 2002HW (JOTUN )	LUCALEN G3710E (LYONDELLBASELL)	LUPOLEN 4552 D SW00413 (LYONDELLBASE LL)
SCOTCHKOTE 226N (3M)		
PE 50-6109 (BASF)	ME 0420 (BOREALIS)	HE 3450H (BOREALIS / BOROUGE)
CORRO-COAT EP-F 2001/2002HW (JOTUN) / JOTAPIPE AC 1003 (JOTUN)		
SCOTCHKOTE 226N(3M)		
CORRO-COAT EP-F 2001(JOTUN)	LE - 149 V (HYUNDAI ENGINEERING PLASTICS)	ET 509 B (HYUNDAI ENGINEERING PLASTICS)

Although the above combinations would be acceptable to Company, the responsibility of suitability for application, performance and compliance to the coating system requirements shall unconditionally lie with the Contractor.

## ANNEXURE – II

PIPE END PROTECTION

The purpose of this specification is to ensure protection of cut back portion of 3LPE coated line pipes.

The specification defines the requirement of cut back protection, application of primer/ varnish, materials and the procedure for application of End Seal Tape in the plant or in field, metallic bevel end protector and pipe end cap.

**2.0 SPECIFICATION**

- 1) FBE band: A  $20 \pm 5$  mm band of epoxy Coating to be maintained in cut-back portion.
- 2) End Seal tape on transition area.

The main purpose of the system is to prevent external pipe coating systems from absorbing moisture and UV- radiation at the cutback area and decrease the risk of coating disbandment from coating/steel transition area during storage period.

**a. Coverage :**

End Seal Tape to be applied over the coating/steel transition area with minimum 50 mm (2inch) overlap on coating and 50 mm (2 inch) beyond the cutback or FBE toe on steel portion.  
i.e total 75 mm(3 inch) considering  $20 \pm 5$  mm FBE toe on steel portion.

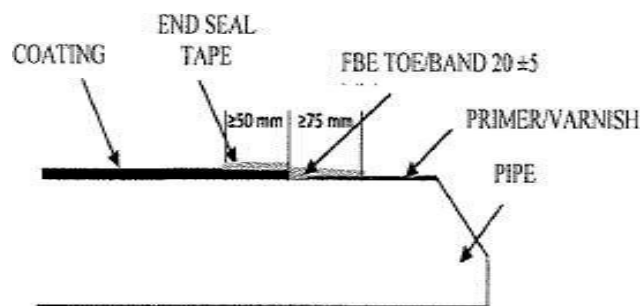

Fig 1 : End seal tape, FBE and primer/ varnish arrangement

**b. Method of application:**

- The coating cutback and the pipe end shall be dry and clean, and free from any visible contaminants. All moisture must be expelled from the pipe surface prior to the application of the End Seal System. For this if required the steel surface shall be warmed above the dew point temperature for a sufficient period of time as to expel all moisture on the pipe.



## PROCUREMENT OF API 5L 3LPE COATED CS LINE PIPE



TENDER DOCUMENT NO:  
GSL/REPL/012/STPL

Date: 19/01/2023

The bare steel pipe on which end seal tape is to be applied shall be free of mud, mill lacquer, wax, oil, grease, rust, mill scale, and any other foreign material that prevents the system from bonding to the steel surface. Prior to surface cleaning, the pipe surface shall be inspected and, if required, pre-cleaned according to SS-PL-001 specification to remove oil, grease, and/or loosely adhering deposits. Visible oil and grease shall be removed by use of a suitable solvent. It shall be ensured that end seal tape at pipe transition area is applied as soon as possible after creation of cut back of 120 mm +20/ (-) 0 mm on each pipe end so that there is no rusting and minimal requirement of cleaning before application of end seal tape. If required before application of end seal tape the pipe surface shall be cleaned to achieve a minimum surface finish as per SSPC-SP3 or Swedish Standard St3.

- The end seal tape shall be applied on the transition area directly to the steel pipe surface. A tight, smooth, wrinkle-free coating shall be maintained throughout the application. At the time of application the steel or coating temperature shall not be above 50°C.
- The End Seal Tape shall be applied at least 50mm (2") from coating cutback to at least 50mm (2") beyond the cutback or the FBE toe, i.e. minimum total length of 125 mm (5"), considering 20 ±5 mm FBE toe on steel portion. Apply 2 full wraps at start and end, with a spirally applied overlap of at least 50% at body.
- The end lap of the splice of each new roll shall overlap the end of the preceding roll by a minimum of 6 inches (153 mm). The end lap splice shall be mechanically applied to insure a wrinkle free splice which maintains the continuity of the anticorrosion layer. The spiral angle of the new roll shall parallel the previous roll's spiral angle.
- Use standard tape application with moderate tension. Ensure that no air is trapped under the tape during installation. Void or entrapped air underneath the tape, if any, shall be worked out using gloved hand or a roller in order to enhance contact. Repair any damage or puncture to the tape during application, handling or the storage of taped pipes by removing and replacing the tape. This is done by removing and replacing the tape or over coating with additional tape if no water penetration has occurred.

### c. Specification:

The tape should be of PVC make and should have adhesive which adheres quickly to most surfaces yet can be removed leaving little or no traceable residue. The tape should meet following requirements:

SL. NO.	DESCRIPTION	REQUIREMENT	TEST METHOD / REMARKS
1	Material	PVC (Polyvinylchloride)	
2	Adhesive Type	Rubber-based	
3	Thickness (min)	≥0.15 mm	
4	Width	50 – 75 mm	



## PROCUREMENT OF API 5L 3LPE COATED CS LINE PIPE



TENDER DOCUMENT NO:  
GSL/REPL/012/STPL

Date: 19/01/2023

5	Adhesion to Steel	$\geq 0.01$ kgf/mm	ASTM D-3330
6	Tensile Strength	$\geq 0.20$ kgf/mm	ASTM D-3759
7	Elongation	$\geq 150\%$	

**d. Inspection & Repair:**

- The end seal tape system shall be electrically tested for flaws in the coating with a suitable holiday detector conforming to NACE standard SP0188-2006.
- Electrical holiday inspection shall be performed on the system upon completion of the coating operation but prior to storage in the coating yard. All holidays electrically detected shall be marked and immediately repaired.

**e. Prior to use the applicator/ contractor shall submit the data sheet and type test report for the end seal tape being used.**

**f. Manufacturer's guidelines on storage and handling of tape shall be followed.**

**g. Following are the approved manufacturer for the end seal tape:**

- 1) M/s Dhatec
- 2) M/s Seal For Life (Formerly Berry Plastics)

OR  
Equivalent

In case other equivalent make/ manufacturer are proposed by applicator / contractor the equivalent make should comply with the requirement of this specification and credentials of manufacturer for previous application for pipe coating cut back protection in hydrocarbon industry, data sheet, details, tape application & removal procedure, test reports, etc. are to be submitted for prior approval.

**h. Removal of end seal tape:**

- If the end seal tape is required to be removal the same should be done when the pipe temperature is below 35°C with the aid of spatula or as per manufacturer's recommendations, low temperature during removal should ensure minimal trace of adhesive residue. Any trace of adhesive residues on pipe/ coating should be readily removable by a solvent wipe, wire brush, or by blasting prior to the field joint coating application.
- If adhesive residual removal is required prior to blasting, it can be readily achieved by natural weathering (tape removed two weeks prior to field jointing), mechanical means or with the use of an appropriate solvent or detergent (should weathering not be an option).

- If adhesive residual removal is required prior to blasting, it can be readily achieved by natural weathering (tape removed two weeks prior to field jointing), mechanical means or with the use of an appropriate solvent or detergent (should weathering not be an option).
- i. **Manufacturer's recommendation on application and removal procedure of endseal tape should be submitted by applicator/contractor.**

### 3.0 Primer/Varnish on cut back area

The uncoated ends shall be protected with compatible primer/ varnish. Applicator/Contractor shall furnish details for the same for approval of Owner and/or TPIA. The pipe surface shall be free of mud, mill lacquer, wax, oil, grease, rust, mill scale, and any other foreign material that prevents the system from bonding to the steel surface. If required the pipe surface shall be cleaned to achieve a minimum surface finish as per SSPC-SP3 or Swedish Standard St3.

### 4.0 Metallic Bevel Protector

All line pipe ends should be protected by fitting metallic bevel end protectors, so that adequate protection is given to the pipe ends. The bevel protector should be designed for absorbing impact forces and offer protection to bevel end in the handling process. Some additional quantity of bevel protector shall be made available at each storage location, which can be used in case of missing protectors before loading/unloading. The bevel protector should have minimum clamping depth of 45 mm and shall be suitable for tightening and clamping the pipe plug. The bevel protector should have a minimum thickness of 1 mm. The bevel protector should have an arrangement of clamping clip for proper tightening.

### 5.0 Pipe Plug

A recessed PVC plug is to be provided at both ends of the pipe. The plug should be suitable for

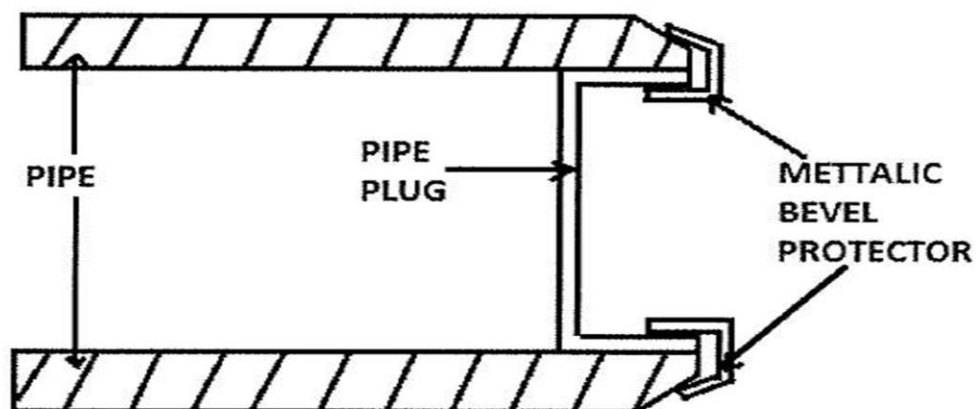

Fig 2: Pipe plug & metallic bevel protector arrangement



## PROCUREMENT OF API 5L 3LPE COATED CS LINE PIPE



TENDER DOCUMENT NO:  
GSL/REPL/012/STPL

**Date: 19/01/2023**

dusty and rainy conditions. The plug on application along should not allow ingress of dust or water inside the pipe. The plug should be tightly clamped inside the pipe with the Steel Bevel Protector. The inside plastic cap is to be placed first and then tightened with the help of metallic bevel protector & clamping arrangement.

The pipe plug should meet following requirements:

SL. NO.	DESCRIPTION	REQUIREMENT
1	Material	LDPE
2	Elasticity at break	$\geq 500\%$
3	Material thickness	$\geq 2$ mm
4	Depth	$\geq 100$ mm

Before application of pipe plug it shall be ensured that inside of the pipe is completely dry and clean. Upon application the bevel protector and pipe plug should be positioned firmly against the pipe. The tightness of plug and bevel protector shall be checked after installation.



**PROCUREMENT OF API 5L 3LPE COATED CS LINE PIPE**



TENDER DOCUMENT NO:  
GSL/REPL/012/STPL

**Date: 19/01/2023**

**INSPECTION AND TEST PLAN**

**FOR**

**WELDED PIPES**

## ABBREVIATIONS

CE	Carbon Equivalent	NDT	Non Destructive Testing
DFT	Dry Film Thickness	NPSH	Net Positive Suction Head
DPT	Dye Penetrant Testing	PO	Purchase Order
DHT	De-hydrogen Heat Treatment	PESO	Petroleum Explosive Safety Organization
ERTL	Electronics Regional Test Laboratory	PQR	Procedure Qualification Record
FCRI	Fluid Control Research Institute	MR	Material Requisition
HT	Heat Treatment	PMI	Positive Material Identification
HIC	Hydrogen Induced Cracking	RT	Radiography Testing
ITP	Inspection and Test Plan	SSCC	Sulphide Stress Corrosion Cracking
IP	Ingress Protection	TC	Test Certificate
IHT	Intermediate Heat Treatment	TPI or TPIA	Third Party Inspection Agency
IC	Inspection Certificate	UT	Ultrasonic Testing
IGC	Inter Granular Corrosion	VDR	Vendor Data Requirement
MPT/MT	Magnetic Particle Testing	WPS	Welding Procedure Specification
MTC	Material Test Certificate	WPQ	Welders Performance Qualification
MRT	Mechanical Run Test		

**SCOPE:**

This Inspection and Test Plan covers the minimum testing requirements of Welded Pipes.

**2.0 REFERENCE DOCUMENTS:**

PO/MR/ Standards referred there in/ Job specifications /Approved documents.

**3.0 INSPECTION AND TEST REQUIREMENTS:**

SL. NO.	STAGE/ ACTIVITY	CHARACTERISTICS	QUANTU MOF CHECK	RECORD	SCOPE OF INSPECTION		
					SUB SUPPLIER	SUPPLIE R	TPIA
<b>1.0</b>	<b>Procedure</b>						
1.1	Hydrostatic Test, Heat Treatment, NDT and Other Procedures	Documented Procedures	100%	Procedure Documents	-	H	R
1.2	WPS,PQR & WPQ	Welding Parameters &Qualification Record	100%	WPS,PQ R&WPQ	-	H	W- New R- Existing( Qualified under reputed TPIA)
<b>2.0</b>	<b>Material Inspection</b>						
2.1	Raw Material Inspection	Review of MTC for Chemical &Mechanical Properties	100%	Test Certificate s	-	H	R

<b>3.0</b>	<b>In Process Inspection</b>						
3.1	Welding	Welding Parameters as per WPS / PQR	100%	Inspection Reports	-	H	-
3.2	Heat Treatment	Stress Relieving, Normalising, Tempering, Solution Annealing, Stabilization Heat Treatment etc. as applicable	100%	HT chart	-	H	R
3.3	Ferrite Check Of SSPipes (If Applicable)	% Ferrite Check	Random OnWeld	Inspection Report	-	H	R
3.4	UT/RT As applicable	Surface & Internal Imperfections	MR / Material Specification	RT Films & UT Test Reports	-	H	R (Film reviewfor RT)
3.5	Identification of TestSamples	Product Chemical, Tensile, Hardness, Impact, IGC and Other test as applicable	Lot as per Specification	Test Reports	-	H	H
3.6	Product Analysis	Chemical Composition	MR / Material Specification	Test Reports	-	H	R
3.7	Destructive Testing	Tensile, Hardness, Impact, IGCand Other test as applicable	Lot as per Specification	Test Reports	-	H	H
3.8	Galvanizing (If Applicable)	Integrity Of Galvanised Coating	100%	Inspection Reports	-	H	R
<b>4.0</b>	<b>Final Inspection</b>						

4.1	Hydrostatic Testing	Leak Check	100%	Test Report	-	H	RW (Min.5% )
4.2	Visual and Dimensional Inspection (VDI	Surface Condition, Straightness, End Finish, Bevel Angle, Root Face, Outer Dia., Thickness, Length, End Finish, Marking etc.	100%	Inspection Report	-	H	RW (Min.5% )
4.3	Weight Checking as applicable	Weight	100%	Inspection Report	-	H	-
4.4	PMI Check	Chemical Check	As Per Spec.	Inspection Report	-	H	RW
4.5	Final Stamping	Stamping of accepted Pipes	Stamping of Pipes which are witnessed by Owner/TPIA	Inspection Report	-	H	H
<b>5.0</b>	<b>Painting</b>						
<b>5.1</b>	Rust Preventive Coating & Colour Coding	Visual & Colour Coding as applicable	100%	Inspection Report	-	H	-
<b>6.0</b>	<b>Documentation &amp; IC</b>						
<b>6.1</b>	Documentation & Inspection Certificate(IC)	Review of Stage Inspection Reports / Test Reports & Issue of IC	100%	Manufacture rTC & IC	-	H	H

**Legend:** H - Hold (Do not proceed without approval), P - Perform, RW - Random Witness (As specified or 10% [min.1 no. of each size and type of Bulk item]), R - Review, W - Witness (Give due notice, work may proceed after scheduled date).

**NOTES (As applicable):**

1. This document describes the generic test requirements. Any additional test or Inspection scope if specified in contract documents shall also be applicable. (Unless otherwise agreed upon)
2. Acceptance Norms for all the activities shall be as per PO/MR/STANDARDS referred there in /Job Specification /Approved Documents.
3. For orders placed on stockist, items shall be accepted based on manufacturer's TC with EN 10204 type 3.2 certification from REPL / OWNER approvedsuppliers.

# **INSPECTION AND TEST PLAN FOR SEAMLESS PIPES**

## ABBREVIATIONS

CE	Carbon Equivalent	NDT	Non Destructive Testing
DFT	Dry Film Thickness	NPSH	Net Positive Suction Head
DPT	Dye Penetrant Testing	PO	Purchase Order
DHT	De-hydrogen Heat Treatment	PESO	Petroleum Explosive Safety Organization
ERTL	Electronics Regional Test Laboratory	PQR	Procedure Qualification Record
FCRI	Fluid Control Research Institute	MR	Material Requisition
HT	Heat Treatment	PMI	Positive Material Identification
HIC	Hydrogen Induced Cracking	RT	Radiography Testing
ITP	Inspection and Test Plan	SSCC	Sulphide Stress Corrosion Cracking
IP	Ingress Protection	TC	Test Certificate
IHT	Intermediate Heat Treatment	TPI or TPIA	Third Party Inspection Agency
IC	Inspection Certificate	UT	Ultrasonic Testing
IGC	Inter Granular Corrosion	VDR	Vendor Data Requirement
MPT/MT	Magnetic Particle Testing	WPS	Welding Procedure Specification
MTC	Material Test Certificate	WPQ	Welders Performance Qualification
MRT	Mechanical Run Test		

**1.0 SCOPE:**

This Inspection and Test Plan covers the minimum testing requirements of Seamless Pipes.

**2.0 REFERENCE DOCUMENTS:**

PO/MR/ Standards referred there in/ Job specifications /Approved documents.

**3.0 INSPECTION AND TEST REQUIREMENTS:**

SL. NO.	STAGE/ ACTIVITY	CHARACTERISTICS	QUANTU MOF CHECK	RECORD	SCOPE OF INSPECTION		
					SUB SUPPLIER	SUPPLIE R	TPIA
<b>1.0</b>	<b>Procedure</b>						
1.1	Hydrostatic Test, Heat Treatment, NDT and Other Procedures	Documented Procedures	100%	Procedure Documents	-	H	R
<b>2.0</b>	<b>Material Inspection</b>						
2.1	Raw Material Inspection	Review of MTC for Chemical, Mechanical Properties, size & steel making process, etc.	100%	Test Certificate s	-	H	R
<b>3.0</b>	<b>In Process Inspection</b>						
3.1	Heat Treatment as applicable	Normalizing, Tempering, Solution Annealing, Stabilization Heat Treatment etc. as applicable	100%	HT chart	-	H	R

3.2	NDT As applicable	Surface & Internal Imperfections	PR / Purchase Specification	NDT Reports	-	H	R
3.3	Identification of TestSamples	Product Chemical, Tensile, Hardness,Impact, IGC and Other test as applicable	Lot as per specification	Test Reports	-	H	H (Note-1)
3.4	Product Analysis	Chemical Composition	Lot as per specification	Test Reports	-	H	R
3.5	Destructive Testing	Mechanical, Impact, IGC and Other test as applicable	Lot as per specification	Test Reports	-	H	H (Note-1)
3.6	Galvanizing (If Applicable)	Integrity Of GalvanisedCoating	100%	Inspection Reports	-	H	R
<b>4.0</b>	<b>Final Inspection</b>						
4.1	Hydrostatic Testing	Leak Check	100%	Test Report	-	H	RW (Note-1)
4.2	Visual and DimensionalInspection (VDI)	Surface Condition, Straightness, End Finish, Bevel Angle, Root Face,Outer Dia., Thickness, Length, End Finish, Marking, End Caps etc.	100%	Inspection Report	-	H	RW (Note-1)
4.3	Weight Checking as applicable	Weight	100%	Inspection Report	-	H	-

4.4	PMI Check	Chemical Check	As Per Spec.	Inspection Report	-	H	R W
4.5	Final Stamping	Stamping of accepted Pipes	Stamping of Pipes which are witnessed by PMC/TPIA. other pipes to have suppliers identification	Inspection Report	-	H	H
<b>5.0</b>	<b>Painting</b>						
5.1	Rust Preventive Coating & Colour Coding as applicable	Visual & Colour Coding as applicable	100%	Inspection Report	-	W	-
<b>6.0</b>	<b>Documentation &amp; IC</b>						
6.1	Documentation & Inspection Certificate(IC)	Review of Stage Inspection Reports / Test Reports & Issue of IC	100%	Supplier TC & IC	-	H	H

**Legend:** H - Hold (Do not proceed without approval), P - Perform, RW - Random Witness (As specified or 10% [min.1 no. of each size and type of Bulk item]), R - Review, W - Witness (Give due notice, work may proceed after scheduled date).

**NOTES (As applicable):**

1. Carbon Steel Pipes (Other than LTCS & Pipes for special services like NACE, H2, HIC, etc.) up to size 12" will be accepted on review of Supplier TestCertificates. Supplier Test Certificate to be reviewed by Owner/TPIA.
2. This document describes the generic test requirements. Any additional test or Inspection scope if specified in contract documents shall also be applicable. (Unless otherwise agreed upon)
3. Acceptance Norms for all the activities shall be as per PO/MR/STANDARDS referred there in /Job Specification /Approved Documents.
4. For orders placed on stockist, items shall be accepted based on manufacturer's TC with EN 10204 type 3.2 certification from REPL / OWNER approvedsuppliers.

**INSPECTION AND TEST PLAN FOR 3-LAYER PE COATING OF LINE PIPES**

## ABBREVIATIONS

CE	Carbon Equivalent	NDT	Non Destructive Testing
DFT	Dry Film Thickness	NPSH	Net Positive Suction Head
DPT	Dye Penetrant Testing	PO	Purchase Order
DHT	De-hydrogen Heat Treatment	PESO	Petroleum Explosive Safety Organization
ERTL	Electronics Regional Test Laboratory	PQR	Procedure Qualification Record
FCRI	Fluid Control Research Institute	MR	Material Requisition
HT	Heat Treatment	PMI	Positive Material Identification
HIC	Hydrogen Induced Cracking	RT	Radiography Testing
ITP	Inspection and Test Plan	SSCC	Sulphide Stress Corrosion Cracking
IP	Ingress Protection	TC	Test Certificate
IHT	Intermediate Heat Treatment	TPI or TPIA	Third Party Inspection Agency
IC	Inspection Certificate	UT	Ultrasonic Testing
IGC	Inter Granular Corrosion	VDR	Vendor Data Requirement
MPT/MT	Magnetic Particle Testing	WPS	Welding Procedure Specification
MTC	Material Test Certificate	WPQ	Welders Performance Qualification
MRT	Mechanical Run Test		

**1.0 SCOPE:**

This Inspection and Test Plan covers the minimum testing requirements of 3-Layer PE Coating of Line pipes.

**2.0 REFERENCE DOCUMENTS:**

PO/MR/ Standards referred there in/ Job specifications /Approved documents.

**3.0 INSPECTION AND TEST REQUIREMENTS:**

SL. NO.	STAGE/ ACTIVITY	CHARACTERISTICS	QUANTU MOF CHECK	RECORD	SCOPE OF INSPECTION		
					SUB SUPPLIER	SUPPLIER	TPIA
<b>1.0</b>	<b>Procedure</b>						
1.1	Coating application, testing and Other Procedures	Documented Procedures	100%	Procedure Documents	-	H	R
<b>2.0</b>	<b>Material Inspection</b>						
2.1	Epoxy powder, Adhesive & Polyethylene compound	All the properties as per Material specification	100%	Manufacturer Test Certificates	H	R	R
<b>3.0</b>	<b>In Process Inspection</b>						
3.1	Epoxy powder, Adhesive & Polyethylene compound check testing	Properties as per Material specification	100%	Test Reports	-	H	H

3.2	Coating Procedure qualification	All the testing as per Material specification	As per Material Specification	Inspection/Test Report	-	H	H
3.3	Incoming Pipes	Visual inspection ,marking verification & correlation with mill TC/Tally sheet	100%	Supplier Data Sheet	-	H	-
3.4	Blast Cleaning	Pre Heating, Elapsed time, Degree of cleaning,, Surface Profile, Contamination of shots/grits, salt level, Degree of dust & roughness	100%	Inspection Reports	-	H	RW (Min.1%)
3.5	Lab test for Chromate, Phosphoric acid & de-ionized water	Properties as per purchase specification / Manufacturer TC	As per Material Specification	Inspection Reports	-	H	RW (Once in a Day)
3.6	Phosphoric acid wash followed by de-ionized water wash	Visual, PH Value, salt level etc.	100%	Inspection Reports	-	H	RW (Once in a Day)
3.7	Chromate Treatment	Uniform application as per Manufacturer's recommendation	100%	Inspection Reports	-	H	RW (Once in a Day)
3.8	Coating application	Preheating temperature, Inter coat time, line speed, Adhesive / PE film temperature, Overlap of layers etc.	100%	Inspection Reports	-	H	RW (Min.1%)
3.9	Epoxy and adhesive Thickness on semi coated pipe	Visual, Thickness, overlap, Adhesion test (St Andrew'sCross Cutmethod) etc.	As per Material Specification	Inspection Reports	-	H	RW (Once in a Day)
<b>4.0</b>	<b>Final Inspection</b>						

4.1	Holiday detection at 25KV	Pin hole, coating damage & Other through thickness defects.	100%	Inspection Report	-	H	RW (Min.1%)
4.2	Visual and Dimensional	Visual, coating thickness, Cut back dimension, Marking , colour coding etc.	100%	Inspection Report	-	H	RW (Min.1%)
4.3	Impact test	No coating damage @ specified Energy	As per Material Specification	Inspection Report	-	H	RW (Once in a Day)
4.4	Peel Test	Bond strength, mode of failure, rate of peeling etc.	As per Material Specification	Inspection Report	-	H	RW (Min.1%)
4.5	Resistance to indentation test	Hardness against indentation	As per Material Specification.	Inspection Report	-	H	RW (Once in a Day)
4.6	Cathodic Disbondment Test	Disbonded area / Equivalent circle radius (ECR)	As per Material Specification	Inspection Report	-	H	W
4.7	Visual ( Air Entrapment)	Air entrapment between the layers	As per Material Specification	Inspection Report	-	H	RW (Min.1%)
4.8	Degree of Cure Test	Cure %, Glass Transition Temp( $\Delta H$ and $\Delta T_g$ )	As per Material Specification	Inspection Report	-	H	RW (Once in a Day)

4.9	Calibration of measuring Instruments/ Holiday tester	Verify Accuracy	As per Material Specification	Calibration Report	-	H	R
4.10	Handling, Load out & Transportation (Bare & coated pipes)	Pipes stacking & weather protection	As per Material Specification	Inspection Report	-	H	-
<b>5.0</b>	<b>Documentation &amp; IC</b>						
5.1	Documentation & Inspection Certificate(IC)	Review of Stage Inspection Reports / Test Reports & Issue of IC	100%	Manufacturer TC & IC	-	H	H
5.1	Final Document submission	Compilation of Inspection / Testreports as per VDR/ PR	100%	Final data folder /Completeness certificate	-	H	H

**Legend:** H - Hold (Do not proceed without approval), P - Perform, RW - Random Witness (As specified or 10% [min.1 no. of each size and type of Bulk item]), R - Review, W - Witness (Give due notice, work may proceed after scheduled date).

**NOTES (As applicable):**

1. This document describes the generic test requirements. Any additional test or Inspection scope if specified in contract documents shall also be applicable. (Unless otherwise agreed upon)
2. Acceptance Norms for all the activities shall be as per PO/MR/STANDARDS referred there in /Job Specification /Approved Documents.